









Installation and maintenance manual

for product line

Eleganza

E3 | E4 | E5



<p>preliminary safety information</p>	<p>Before using the machine, carefully read this information that helps you behave properly and guarantees a safe use. The following pages use the symbols listed here below, whose meaning is of attention:</p>
	<p>GENERAL If the text is highlighted by this symbol, it is recommended to pay special attention to the performance of the procedures described; if not carefully performed on safe conditions, they can be source of general danger.</p>
	<p>HIGH VOLTAGE If not properly performed, the actions marked by this symbol may expose to accidental contacts with electric voltage.</p>
	<p>DANGEROUS TEMPERATURE If not properly performed, the actions marked by this symbol may expose to accidental contacts with high-temperature parts.</p>
	<p>MOVING MEMBERS If not properly performed, the actions marked by this symbol may expose to accidental contacts with moving members.</p>
	<p>CRUSHING If not properly carried out, the actions marked by this symbol may expose to a risk of crushing. The same symbols are placed inside the vending machine to indicate the parts on which to act with the utmost caution.</p>
	<p>SERVICE KEY IN USE The symbol recommends the utmost attention during the actions described; the use of the service key activating all machine functions when the door is open is only reserved to the technical operators who know the operation of the vending machine, who are aware of its potential risks and who make sure they are operating on totally safe conditions. The use of the service key shall be strictly limited to the time necessary to perform the actions requiring the use thereof; users shall be informed of the prohibition on using and approaching the vending machine.</p>
	<p>WEIGHT The symbol reminds the user to consider the machine weight carefully for handling and placing it definitively.</p>
	<p>WATER SUPPLY It marks the parts duly requiring caution in case of leakage, if connected to the water mains.</p>
	<p>SUPPORT SURFACE It reminds the user to install the machine on a support surface, the max. inclination of which is 2°.</p>

safety standards for using the vending machine





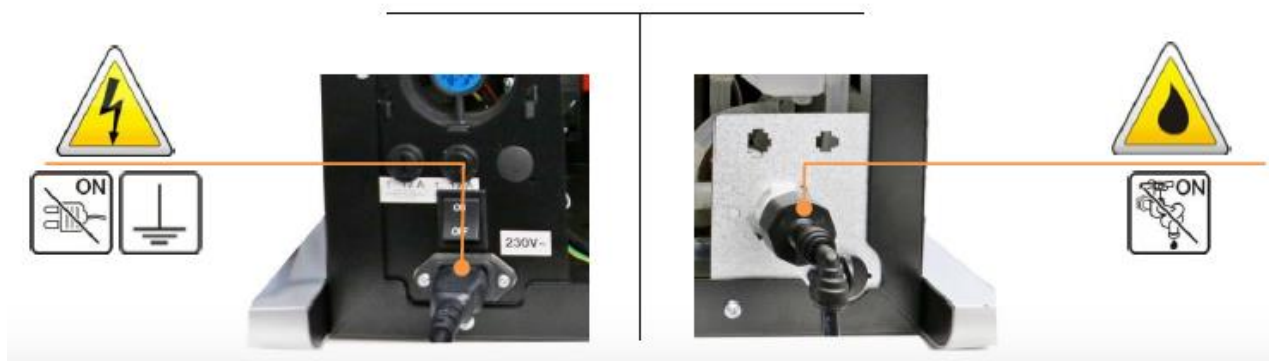
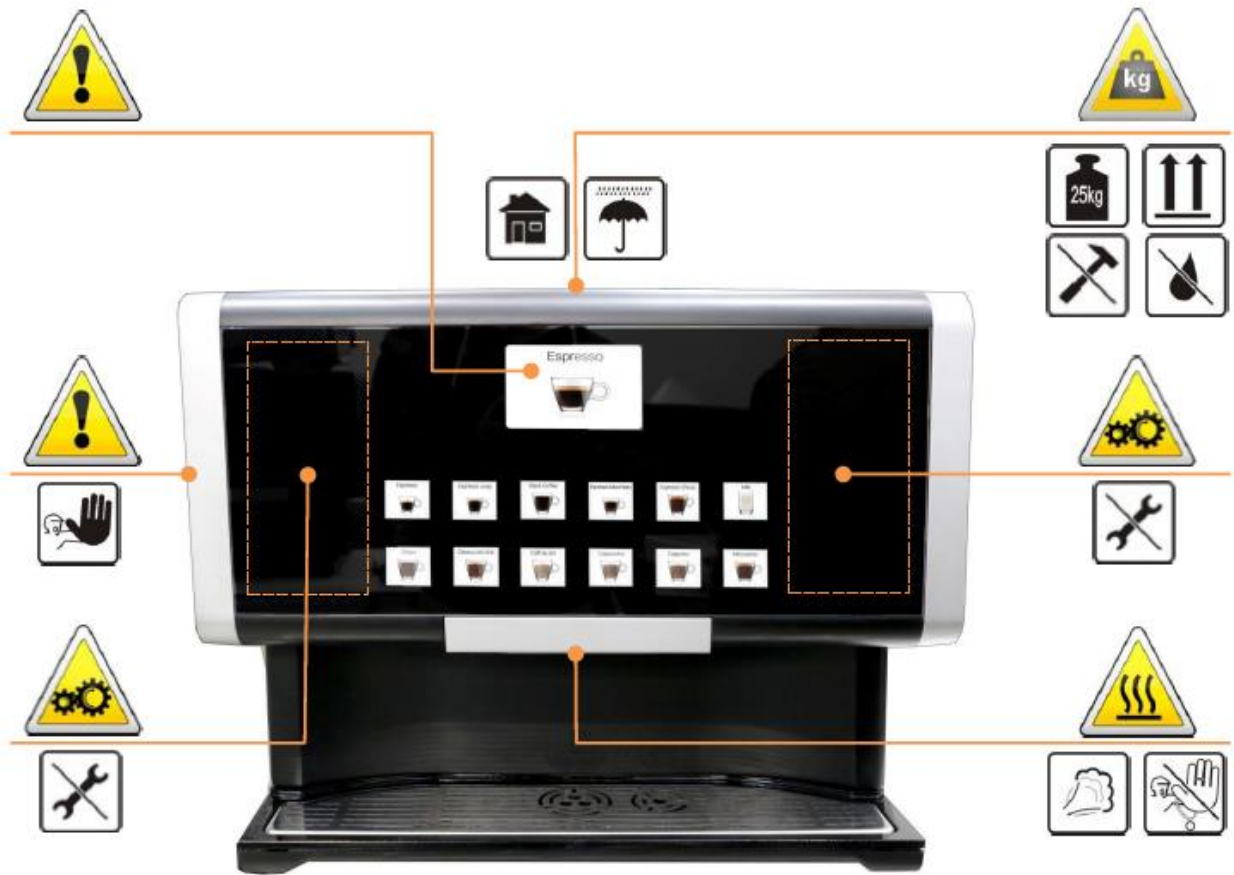





***	pay special attention to the chapters and notes highlighted by the symbols of alert and strictly observe the rules concerning, in particular, the operators' and users' safety;
***	the vending machine may be used by children who are at least 8 years old and by people having reduced physical, sensory or mental capacities or not having all necessary experience and knowledge, provided that they are supervised or instructed on how to use the machine safely and they have well understood the dangers related thereto; children must be supervised and prevented from playing with the vending machine; cleaning and servicing shall not be carried out by children;
***	if you should find out a water leak or the presence of smoke, ... immediately <u>detach</u> the vending machine from the electric and hydraulic network, never try to restore its operation and apply to skilled technicians;
***	the machine shall be installed according to national rules; pay special attention to the rules about the machines directly connected with the hydraulic network;
***	ambient (during storage and operation): temperature: 5 °C ÷ 35 °C relative humidity: maximum 80%
***	the inclination of the support surface of the vending machine shall not exceed 2°;
***	if the hydraulic connection tube is not supplied with the machine or in case of replacement, the connection must be carried out only with: <ul style="list-style-type: none"> ▪ a new tube; ▪ whose material is type-approved for food use; ▪ compliant with "IEC 61770 Electric appliances connected to the water mains"; ▪ capable of supporting the operating pressure;
***	the user is not allowed to access the maintaining and servicing area that shall be properly signaled;
***	never remove protections, never override safety devices and never modify the machine or its components;
***	tools necessary to act with this vending machine: <ul style="list-style-type: none"> ▪ a pair of scissors for electricians, a Phillips PH2 cross screwdriver for 4/6 mm self-threading screws, a set of wrenches up to 13 mm, a set of Allen wrenches from 2 to 8 mm; ▪ it may be of use to procure some expendables, such as disposable paper, single-use gloves, clean cloth, cups and a bucket for waste water collection;
***	never wash the machine by using water jets; the vending machine is not suitable for installation in areas where it can be reached by water jets;
***	for cleaning at regular intervals refer to chapter 12;

safety rules for using the vending machine





	<p>The symbol means that it is forbidden to dispose of the equipment as urban waste and compulsory to provide for separate collection in order to prevent any potential effect on the environment and human health; strictly follow the provisions of the European Parliament's Directive 2012/19/EU.</p>	
--	---	--



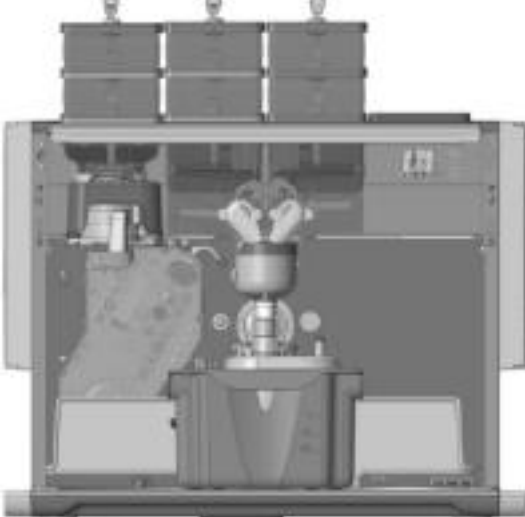
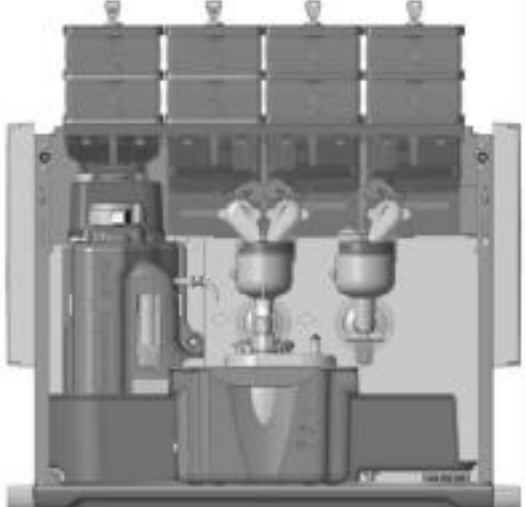
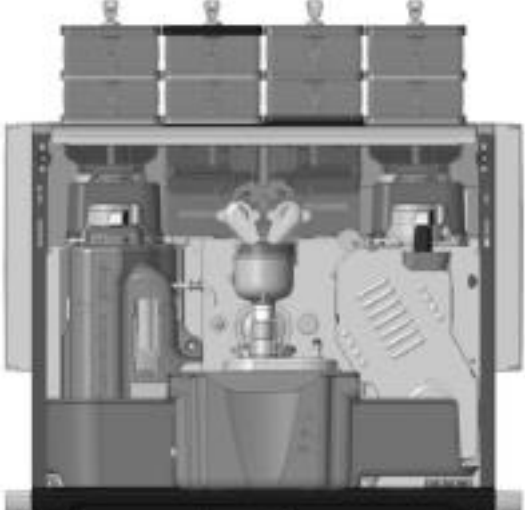

residual risks

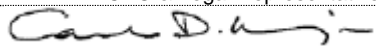
	<p>A residual risk is understood as a potential danger that can't be eliminated and it persists despite all precautions in use since it is related to the intrinsic features of the product and it also includes non- identifiable risks. The actions and behaviours listed here below are intended to reduce residual risks and you shall always adopt them when interacting with the machine.</p>	
	<p>Wear clothes that can properly avoid any accident (never wear rings, chains, clothes with laces or excessively long sleeves, ...).</p>	
	<p>Carefully evaluate the treatment of residues from installation (wood, plastics, ...) and utilisation (product powder, bags, ...).</p>	
	<p>Never repair or carry out any technical action if you have not been properly trained.</p>	
	<p>Signal that a technical action is in progress on the machine (barriers against approach, signs, ...), carry it out quickly without leaving the station.</p>	
	<p>Install the machine in a sheltered, illuminated, ventilated and noiseless environment; keep it clean and never place tools or any other object on it; never install it outdoors or, anyway, never expose it to atmospheric agents.</p>	
	<p>Make sure it can be neither reached by water sprays or vapours nor hit by objects that might damage it.</p>	
	<p>Carefully consider the machine weight and stability during the installation and in the final working position.</p>	
	<p>Supply the machine within voltage, temperature, pressure and water limits, ... as it is detailed on the following pages and provide for an effective earthing.</p>	
	<p>Even if detached from supplies, the machine may contain pressurised hot water at a high temperature.</p>	
	<p>Never detach hydraulic and electric supplies when they are active.</p>	

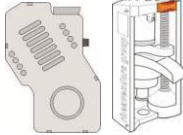

This manual is intended to describe the Eleganza-series vending machine in its versions; by using the same basic components, the three machines differ from each other in components and in the features specified later on; the descriptions supplied by this document are shared by all three versions, if not otherwise specified by the text or by the icons typical of every single model.

	<p>Eleganza E3</p> <p>Micro brewer</p> <ul style="list-style-type: none"> 1 Bean container 2 instant canisters 1 mixing bowl hot water (separate outlet) 582 x 452 x 522 mm (w x h x d) <u>pressure boiler 400 cc. 1500 W</u>
	<p>Eleganza E4</p> <p>Combiflex brewer</p> <ul style="list-style-type: none"> 1 bean container 3 instant canisters 2 mixing bowls hot water (separate outlet) 582 x 452 x 522 mm (w x h x d) <u>pressure boiler 400 cc. 1500 W</u>
	<p>Eleganza E5</p> <p>Combiflex brewer</p> <p>Micro brewer</p> <ul style="list-style-type: none"> 2 bean containers 2 instant canisters 1 mixing bowl hot water (separate outlet) 582 x 452 x 522 mm (w x h x d) <u>pressure boiler 400 cc. 1500 W</u>

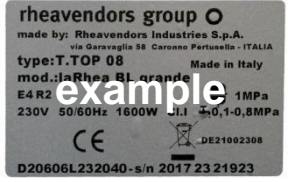
<p>declaration of conformity</p>	<p>Rheavendors Industries S.p.A. declares that this drink vending machine has been designed and manufactured in compliance with the following directives and safety standards:</p>																	
	<p>Directives: 2014/30/EU; 2014/35/EU; 2006/42/EC; 2014/68/UE; 2011/65/EC (RoHS); 2012/19/EU (RAEE);</p>																	
	<p>Regulations: 1907/2006/EC (REACH); 1935/2004/EC;</p>																	
	<p>Standards: SAFETY: EN 60335-1: 2012 + A11: 2014 + A13: 2017; EN 60335-2-75: 2004 + A1: 2005 + A11: 2006 + A2: 2008 + A12: 2010;</p>																	
	<p>EMC: EN 55014-1: 2006 + A1: 2009 + A2:2011; EN 55014-2: 2015; EN 61000-3-2: 2014; EN 61000-3-3: 2013;</p>																	
	<p>EMF: EN 62233: 2008;</p>																	
	<p>manufacturer</p>																	
	<p>Rheavendors Industries S.p.A Via Valleggio, 2/bis – 22100 Como – (CO) - Italien</p>																	
	<p>factory</p>																	
	<p>Rheavendors Industries S.p.A Via Garavaglia, 58 - 21042 Caronno Pertusella – (VA) – Italien</p>																	
	<p>CEO & Legal Representative</p>																	
	 (C. D. Majer)																	
<p>marking</p>	<p>conformity</p> 																	
<p>ISO 9001- certification</p>	<div style="display: flex; justify-content: space-around;"> <div data-bbox="518 1489 837 1937"> </div> <div data-bbox="853 1489 1173 1937"> <table border="1" data-bbox="885 1590 1157 1668"> <thead> <tr> <th>Site Name</th> <th>Site Address</th> <th>Site Scope Limit</th> <th>Site Status</th> </tr> </thead> <tbody> <tr> <td>RHEAVENDORS INDUSTRIES S.p.A. - Sede Operativa</td> <td>Via Valleggio, 2/bis - 22100 Como - (CO) - Italia</td> <td>Progettazione di gruppo</td> <td>Referenza to scope</td> </tr> <tr> <td>RHEAVENDORS INDUSTRIES S.p.A. - Sede Operativa</td> <td>Via Valleggio, 2/bis - 22100 Como - (CO) - Italia</td> <td>Progettazione di gruppo</td> <td>Referenza to scope</td> </tr> <tr> <td>RHEAVENDORS INDUSTRIES S.p.A. - Sede Operativa</td> <td>Via Garavaglia, 58 - 21042 Caronno Pertusella (VA) - Italia</td> <td>Progettazione di gruppo</td> <td>Referenza to scope</td> </tr> </tbody> </table> </div> </div>	Site Name	Site Address	Site Scope Limit	Site Status	RHEAVENDORS INDUSTRIES S.p.A. - Sede Operativa	Via Valleggio, 2/bis - 22100 Como - (CO) - Italia	Progettazione di gruppo	Referenza to scope	RHEAVENDORS INDUSTRIES S.p.A. - Sede Operativa	Via Valleggio, 2/bis - 22100 Como - (CO) - Italia	Progettazione di gruppo	Referenza to scope	RHEAVENDORS INDUSTRIES S.p.A. - Sede Operativa	Via Garavaglia, 58 - 21042 Caronno Pertusella (VA) - Italia	Progettazione di gruppo	Referenza to scope	
Site Name	Site Address	Site Scope Limit	Site Status															
RHEAVENDORS INDUSTRIES S.p.A. - Sede Operativa	Via Valleggio, 2/bis - 22100 Como - (CO) - Italia	Progettazione di gruppo	Referenza to scope															
RHEAVENDORS INDUSTRIES S.p.A. - Sede Operativa	Via Valleggio, 2/bis - 22100 Como - (CO) - Italia	Progettazione di gruppo	Referenza to scope															
RHEAVENDORS INDUSTRIES S.p.A. - Sede Operativa	Via Garavaglia, 58 - 21042 Caronno Pertusella (VA) - Italia	Progettazione di gruppo	Referenza to scope															

<p>01. legend</p>	<p>some general instructions that may be of use for reference to this manual;</p>	
<p>01.01. abbreviations and pictograms</p>	<p>I = dispensing cycle of drinks based on instant products E = dispensing cycle of drinks based on instant products and coffee beans; A = machines with internal water tank R = machines with external water supply  = mixer for mixing the instant product with water VSF = worm screw pitch in the product canister § = product shaker of instant canisters</p>	
	<p>= espresso coffee brewer</p>	
	 = hot water dispenser	
	 = maximum operating pressure of the boiler	
	 = water supply pressure range of the vending machine	
<p>02. introduction</p>		
<p>02.01. copyright information</p>	<p>This manual is intended for the owner of the vending machine; it is an integral part of the machine and it shall be kept with it;</p> <p>The information supplied by this manual are intended to achieve the best performances of the vending machine within the scope of application established by the Manufacturer; Rheavendors Industries S.p.A. reserves the right to improve future production without serving any prior notice and without assuming any obligation to update the products on the market; the manufacturer will disclaim all responsibility for any inaccuracy due to misprints;</p> <p>the a.m. chapters of the manual are intended to describe vending machines eleganza E3 – E4 – E5 in their hardware and software components for a complete and fully-aware use of all machine functions; due to the large variety of available options and the constant technical update of our vending machines, some special device or function might be indicated and described not in the manner you expect; in this case, do not hesitate to contact us;</p>	
<p>02.02. contacts</p>	<p>coffee perfect. is ready to supply support and information on this vending machine;</p> <p style="text-align: center;">Denmark telephone: 0045 787 93 108 e mail: info@coffee-perfect.dk</p>	
<p>02.03. serial number labels</p>	<p>To be able to identify the vending machine rapidly and univocally as well as to get the best support, please specify the data of the serial number label;</p> <p style="text-align: center;">Code: D12345A67890 (example) S/N: 1234 56 7890 (example)</p> <p>silvery serial number labels are applied inside and outside the case of the machine.</p>	

03. technical data		
03.01. dimensions	height: height (including visible canister): width: depth: depth with open door:	452 mm 506 mm 582 mm 522 mm 942 mm
03.02. mass	Eleganza E3 Eleganza E4 Eleganza E5	34,5 kg 36,4 kg 37,4 kg
03.03 supply		
	water	<ul style="list-style-type: none"> ▪ connection by means of a solenoid valve with 3/8" gas male face ▪
	energy	<ul style="list-style-type: none"> ▪ 230 V, 50/60 Hz; single-phase and ground; ▪ cable of the following type: H05VV-F 3G 1 mm² 300/500 V
		from 0,1 MPa to 0,8 MPa
		E: 1.600 W
	values and indications for standard machine anyway refer to serial number label data	
		see 02.03.
03.04. sound pressure	A-weighted sound pressure level	less than 70 dB(A)
03.05. keyboard	capacitive keyboard, without moving parts; twelve selection buttons	
03.06. display	4,3" multicolor TFT	resolution 480 x 282
03.07. dispensing cpt.	open	maximum 150 mm
03.08. drip tray	drip tray beneath the cup surface	capacity 750 ml
03.09. dispenser	a fixed dispensing place	
03.10. safety		
	water	overflow sensor and pressure relief valve; in all machines water inlet solenoid valve with anti-flood sensor
	energy	a main switch, a door switch; two 6.3x32 mm fuses
	heat	manually resettable sensors
	software	time limits for water dispensing cycles
03.11. grinder motor	espresso machine	230 V dc; 150 W
03.12. grinders	conical	400 r.p.m.
03.13.		
Espresso brewer PRO	variable-volume brewing chamber; two diameters alternatively between them containing, according to the grinding degree: motor	Ø 36 mm; 5 ÷ 9 gr. Ø 45 mm; 8 ÷ 15 gr. 24 V dc; 30 W
Espresso brewer MICRO	reversed	
03.14. air break	air break with overflow and level switch	
03.15. pump	vibration pump with bypass	24 V dc; 230 V ac; 1,0 MPa
03.16. product motors	Je nach Geräteausführung	95 r.p.m. 24 V dc
03.17. mixing bowls	according to the machine configuration	
03.18. mixer motors	max. two, according to the machine configuration	15.000 r.p.m. 24 V dc
03.19. boiler	espresso machine: pressurised boiler	0,4 liters, 1.500 W maximum 1,0 MPa

<p>03.20. product canisters</p>	<p>according to the machine configuration; dispensing worm screws 9 mm or 18 mm in pitch; with mixer gear and with standard or shorter product chute outlet</p> <p>coffee beans canister capacity (with one canister extension,): app. 700 g</p> <p>instant canister capacity (with one canister extension,): app. 1.700g Milk Powder app. 2.200g Cacao app. 2.200g Vanilla</p> <p>canister extension: increases +1.25 liters, nominal</p> <div style="text-align: center;">  </div> <p>machines and components have been tested with standard products; if you plan to use specific non-conventional products our customer service is available for preventive testing that may also affect the choice of some machine components.</p>	
<p>03.21. miscellaneous</p>	<p>Machine parameters programmable by means of a flash key, a USB key or selection keyboard; NRI G13 or similar payment system compartment; protocols: serial, parallel, executive, MDB; data collection by means of a USB or flash key (see 05.41.).</p>	
<p>03.22. notes</p>	<p>The water and energy supply tolerance limits that can ensure a good and proper operation of the machines are:</p>	
	<p>water</p>	
	<ul style="list-style-type: none"> ▪ total hardness: ▪ recommended conductivity: <p>(*if harder, please use anti-limestone filters;</p>	<p>from 10 °f to 25 °f (*) 400 µS @ 20 °C</p>
	<p>energy</p>	
	<ul style="list-style-type: none"> ▪ nominal voltage 	<p>+10 % /- 15 %</p>
	<p>room (during storage and operation)</p>	
	<ul style="list-style-type: none"> ▪ temperature: ▪ relative humidity: 	<p>5 °C ÷ 35 °C Max. 80 %</p>
	<p>electric consumption</p>	
	<ul style="list-style-type: none"> ▪ power (stand-by / vending phase): E: <p>The complete data according to the EVA-EMP Energy Measurement Protocol, are made available upon request (see 02.02.).</p>	<p>38 Wh/h / 380 Wh</p>
<div style="text-align: center;">   </div>	<p>The power supply cable supplied with the vending machine shall not be altered under any circumstance; in case of loss or damage, only the personnel authorised and qualified may replace it with an original component only.</p>	
	<p>Make sure that the electric installation can deliver the power suitable for the machine (see 03.03.). A good ground connection is not only a legal obligation for the protection of users and operators, but it can also provide for correct.</p>	

04. configurations		
04.01. formalisms	Vending machines configurations are numerous; they are coded by means of some categories exemplified here below in the abbreviation of the machine::	
a. product canisters	<ul style="list-style-type: none"> ▪ instant products and coffee beans: ▪ instant products and two different coffee beans: 	Eleganza E3 and E4 Eleganza E5
b. water supply	<ul style="list-style-type: none"> ▪ external, by means of the inlet solenoid valve: ▪ from the external module of the vending machine: 	
c. numbering	product canisters, mixing bowls and mixers are numbered in progression, from the left to the right, as it is shown later on; this numbering is used in the chapter on how to programme (see 09.) drinks.	
04.02. examples of configurations		

Eleganza E3	Eleganza E4	Eleganza E5
<ul style="list-style-type: none"> ▪ Micro Brewer ▪ 1 bean canister ▪ 2 instant canisters ▪ 1 mixing bowl ▪ hot water (separate outlet) 	<ul style="list-style-type: none"> ▪ Combiflex- brewer ▪ 1 bean canister ▪ 3 instant canisters ▪ 2 mixing bowls ▪ hot water (separate outlet) 	<ul style="list-style-type: none"> ▪ Combiflex brewer ▪ Micro brewer ▪ 2 bean canisters ▪ 2 instant canisters ▪ 1 mixing bowl ▪ hot water (separate outlet)

04.03. accessories	<p>The configurations above are just some of possible configurations, considering the vending machine releases and programmability; the principles of operation and information are anyway universal and applicable to all machines range.</p> <p>To complete and supplement the vending machines range, coffee perfect has got a series of accessories manufactured for these machines, such as cabinets, autonomous water supply kits, payment systems, connection with machines intended to dispense cold drinks.</p> <p>coffee perfect is at disposal for any kind of support and information on special configurations (see 02.02.).</p>	
--------------------	---	--

05. control panels and components: Eleganza E5

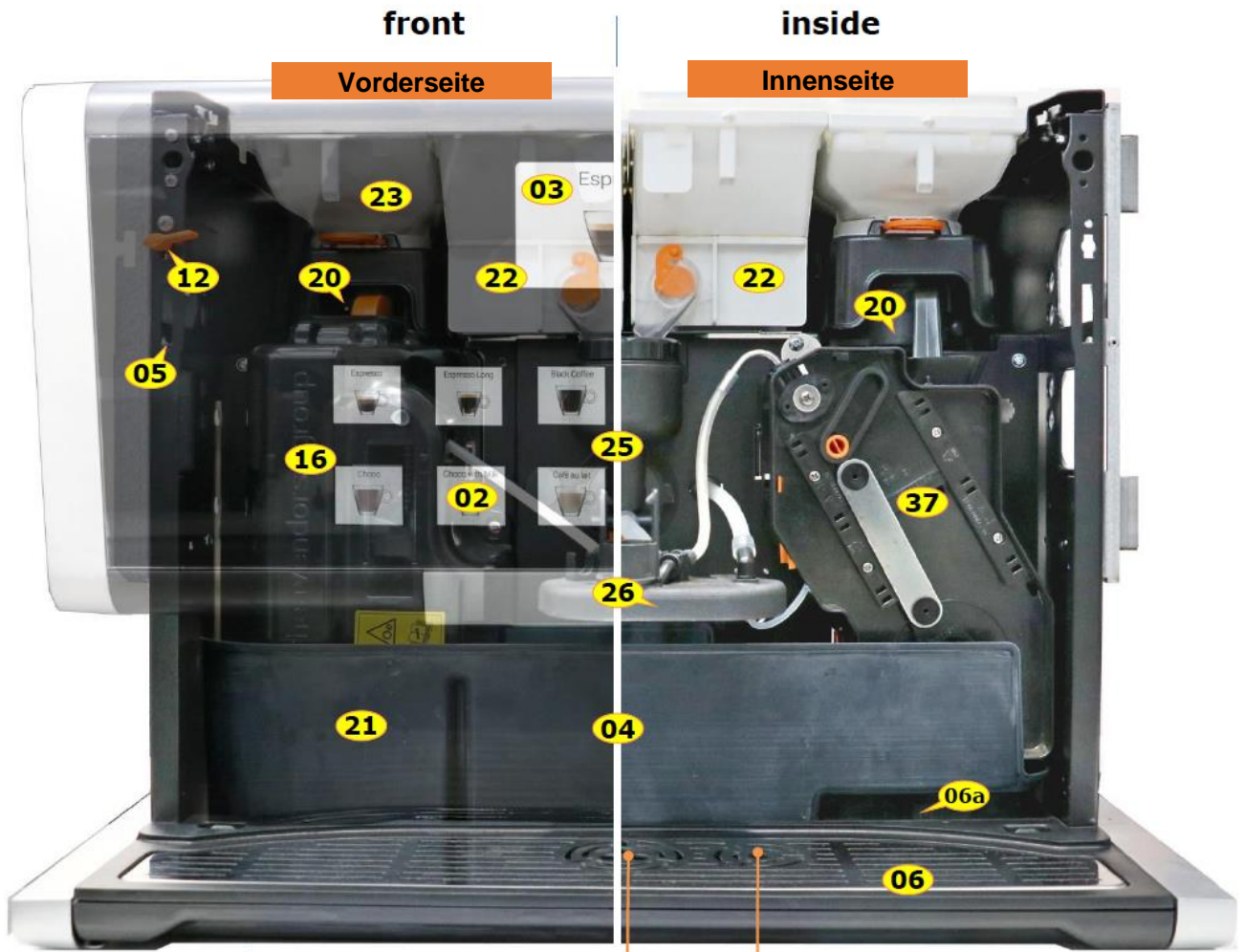

beverages

Hot water (direct)

Getränke





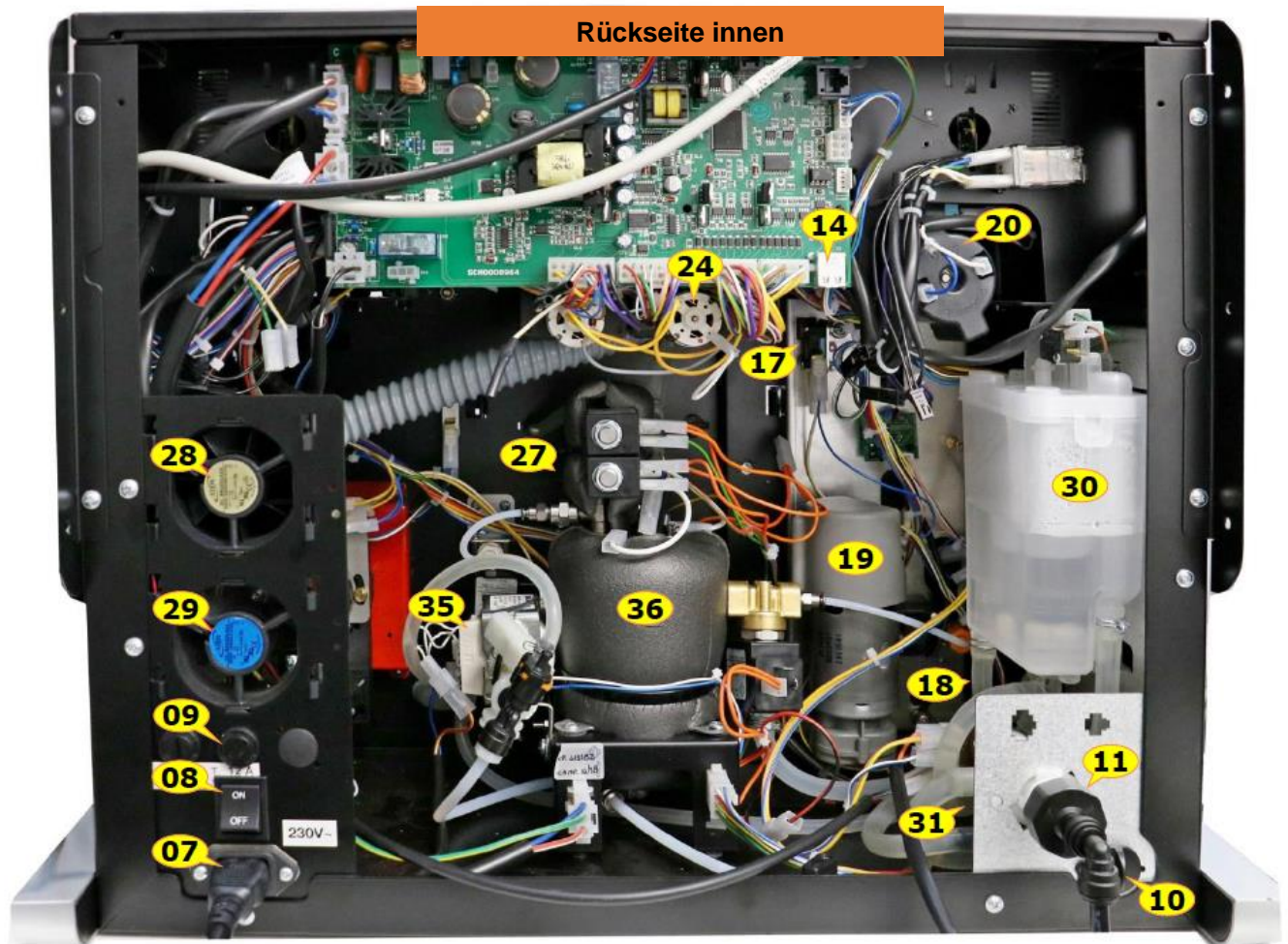

Heißwasser (direkt)

02. selection keyboard	20. grinder
03. display	21. grounds container
04. dispenser	22. product canisters
05. door lock	23. coffee beans canister
06. drip tray	24. product motors
06a. dispenser sensor	25. mixing bowls
07. electric connection	26. nozzle support
08. power on switch	27. mixer motor
09. fuses	28. powder aspirator
10. water drain plug	29. air aspirator
11. water inlet solenoid valve	30. air break
12. door switch	31. volumetric counter
13. Interne Taste (PROG)	32. door lighting
14. USB-Speicheranschluss	33. cup sensor
15. Taschen für Produktschilder	34. ---
16. Kaffeebrüher Combiflex	35. pressure boiler pump
17. Sensor Brüher vorhanden	36. pressure boiler
18. Kaffeebrüherheizung	37. coffee brewer Micro
19. Kaffeebrühermotor	

rear inside



02. selection keyboard	20. grinder
03. display	21. grounds container
04. dispenser	22. product canisters
05. door lock	23. coffee beans canister
06. drip tray	24. product motors
07. electric connection	25. mixing bowls
08. power on switch	26. nozzle support
09. fuses	27. mixer motor
10. water drain plug	28. powder aspirator
11. water inlet solenoid valve	29. air aspirator
12. door switch	30. air break
13. ---	31. volumetric counter
14. USB key housing	32. ---
15. ---	33. ---
16. coffee brewer Variflex/Micro	34. ---
17. brewer presence switch	35. pressure boiler pump
18. coffee brewer heater	36. pressure boiler
19. coffee brewer motor	37. brewer for Fresh leaf tea

<p>05.01 general information</p>	<p>The Eleganza-series vending machine is a machine explicitly designed for being easily used by all users since no specific competence is required in preparing drinks.</p>	
	<p>The function consists in dispensing drinks by mixing food products and water at a proper temperature; the correct operation of the vending machine occurs in closed rooms in normal environmental conditions and at a room temperature between 5 °C and 35°C, the relative humidity below 80%.</p> <p style="text-align: center;">Use only specific ingredients for vending machines.</p> <p>Dispense by briefly pressing a key of the selection keyboard (see 05.02.); make sure that the cup has been properly positioned at the dispensing station.</p>	
<p>05.02. selection keyboard</p>	<p>After having closed the door, press the buttons to dispense; all buttons are lighted in standby mode whereas they turn off during the dispensing cycle and only the selected button turns on; keys will assume various functions in the programming mode (see 09.) and enable the user to modify the machine parameters; keys are numbered progressively from the top: 1, 2, ... and from the left.</p>	
<p>05.03. display</p>	<p>The display messages inform users and operators about the operation state of the vending machine.</p>	
<p>05.04. dispenser</p>	<p>The Eleganza series vending machine has got a fixed drink dispenser on the cup support surface.</p>	
<p>05.05. door lock</p>	<p>The door is closed by means of a lock; the key is mapped and numbered for identification.</p>	
<p>05.06. drip tray</p>	<p>It collects possible residual drops from the dispenser and, if necessary, the waste water in excess from three-way valve; it is slid at the bottom of the machine case, in the front, and it is composed by a covering drawer and a grilled cover that can be washed by running water; an electric contact is intended to control the filling level (see 11. and 13.03.).</p>	
<p>05.07. electric connection</p>	<p>A three-terminal socket is arranged at the back of the case for the connection of the mains cable.</p>	
<p>05.08. power on switch</p>	<p>To power on and off the machine.</p>	
<p>05.09. fuses</p>	<p>installed on the mains power supply (see 03.10.); fuses must be necessarily replaced by specialised technical personnel only.</p>	
<p>05.10. water drain plug</p>	<p>From where to let the silicone tube from the air break or from the boiler come out for emptying; it is fixed with a screw to the rear panel.</p>	
<p>05.11. water inlet solenoid valve</p>	<p>The water inlet solenoid valve on machines has got an anti-flood safety device intended to stop the water inlet in case of failures; to its electrical pins can be connected in parallel on water.</p>	
<p>05.12. door switch</p>	<p>To power off the machine when the door is open.</p>	
	<p style="text-align: center;">Attention</p> <p style="text-align: center;"><u>Some parts remain anyway network-connected act extremely carefully.</u></p> <p>Use the service key to supply the vending machine if it is necessary to activate the machine when the door is open; the service key is housed in the cover and its use is reserved to the properly trained technical personnel only.</p>	

05.13. internal button (PROG)	The button giving access to the machine programming mode is arranged on the orange protection carter inside the door (PROG).	
05.14. USB key housing	Programming USB key are arranged in the display board behind the orange protection carter inside the door.	
05.15. label pockets	Product labels are arranged inside the door panel, beneath the orange carter. Insert the labels into the pockets by observing the machine configuration (see 13.02.).	
05.16. coffee brewer	After receiving the coffee dose from the grinder and compressing it, percolation occurs in the coffee brewer with the water from the pump; the used dose is conveyed towards the slide and the drawer at the bottom of the machine; the structure of the brewer is kept at the correct temperature by a hot air heating system programmable via software (see 09.01.e.).	
05.17. brewer presence switch	The coffee brewer presence is controlled by a micro-switch that can inhibit the selections including coffee beans, if it is not present.	
05.18. coffee brewer heater	A safety cover is intended not only to protect the operator against moving parts, but also to keep the coffee brewer at the correct temperature through an air heater preserving the drink quality even after a long vending machine pause.	
05.19. coffee brewer motor	The variable coffee brewer motor is intended to regulate the chamber closing and compressing phases in order to compress ground coffee for its percolation; its action is controlled by an encoder that informs the CPU on the brewer position.	
05.20. grinder	It grinds the coffee beans in the canister to pour it in the coffee brewer chamber; the grinding degree can be manually adjusted by means of the wheel you can access after removing the coffee canister whereas the ground quantity is determined by a software parameter (see 09.01.a "grinder time") that establishes the grinder work time.	
05.21. grounds container	It collects about fifty ground doses after having used them in the coffee brewer; a software option (see 09.01.o.) will show a warning message as soon as the tray is full.	
05.22. product canisters	Instant product canisters dispense their content in the underlying mixing bowls; an internal worm screw driven by the product motor will push the instant product to the product chute; they can be equipped with a wheel and a product shaker for constant dispensing; the outlet, the dimension of which can be either standard or smaller, has got a closing baffle.	
05.23. coffee beans canister	The coffee beans canister (hopper) has got a closing orange blade that is to be inserted before lifting the canister; canisters are closed by a cover to protect products.	
05.24. product motors	They are intended to rotate the worm screws inside instant product canisters to pour the product quantity necessary for selection in the mixing bowls.	

<p>05.25. mixing bowls</p>	<p>The mixing bowls of the mixers will accommodate the instant products you have poured to mix them with water; the fan of mixer motors will act at the bottom and the drink outflow to the dispenser occurs by means of a silicone tube; mixing bowls and outlet tubes can be washed with lukewarm running water.</p>	
<p>05.26. nozzle support</p>	<p>A fixed support on the cup station is intended to accommodate the three dispensers coming from the mixing trays of mixers and the direct hot water.</p>	
<p>05.27. mixer motor</p>	<p>The motors of mixers help you mix instant products with water by means of the rotation of the fan mounted on their axis; the rotation speed can be adjusted (see 09.01.a.) to the features of the various products.</p>	
<p>05.28. powder aspirator</p>	<p>An aspirator will eject suspended product residuals from the vending machine; the aspirator is connected with a drawer beneath product chutes to intercept the residual impalpable powder coming from selections; the action time of the aspirator is programmable by means of a software parameter (see 09.01.f.); aspirated air is ejected through the slots of the rear panel.</p>	
<p>05.29. air aspirator</p>	<p>To aspirate the air from the internal environment of the machine to avoid any condensate.</p>	
<p>05.30. air break</p>	<p>In the Eleganza-series, it accumulates water for sending to the pressure boiler; the level is controlled by a float and – if above the established level – it will flow back to the inlet solenoid valve safety device, thus preventing the inlet of new water.</p>	
<p>05.31. volumetric counter</p>	<p>For the espresso version only, it supplies the CPU the water quantity running through the coffee brewer to establish its volume; the water quantity of instant selections is established by the time set in the “water N” parameter only (see 09.01.a.).</p>	
<p>05.32. door lighting</p>	<p>The cup station and the logo are lit up by a module mounted inside.</p>	
<p>05.33. cup sensor</p>	<p>If installed and enabled, it disables the keyboard selection preventing the delivery, as long as it does not recognize that the cup is positioned in the dispensing compartment.</p>	

	<p>attention <u>These components may be very hot even if the machine is off.</u></p>	
<p>05.34. pressure boiler pump</p>	<p>in the E machine, a vibration pump with bypass conveys water to the solenoid valves block for instant and three-way valve for espresso.</p>	
<p>05.35. pressure boiler</p>	<p>in the E machine, pressure boiler complete with a temperature probe and protection clicsons; the drain tap may be used to empty the hydraulic circuit (see 09.01.f.).</p>	

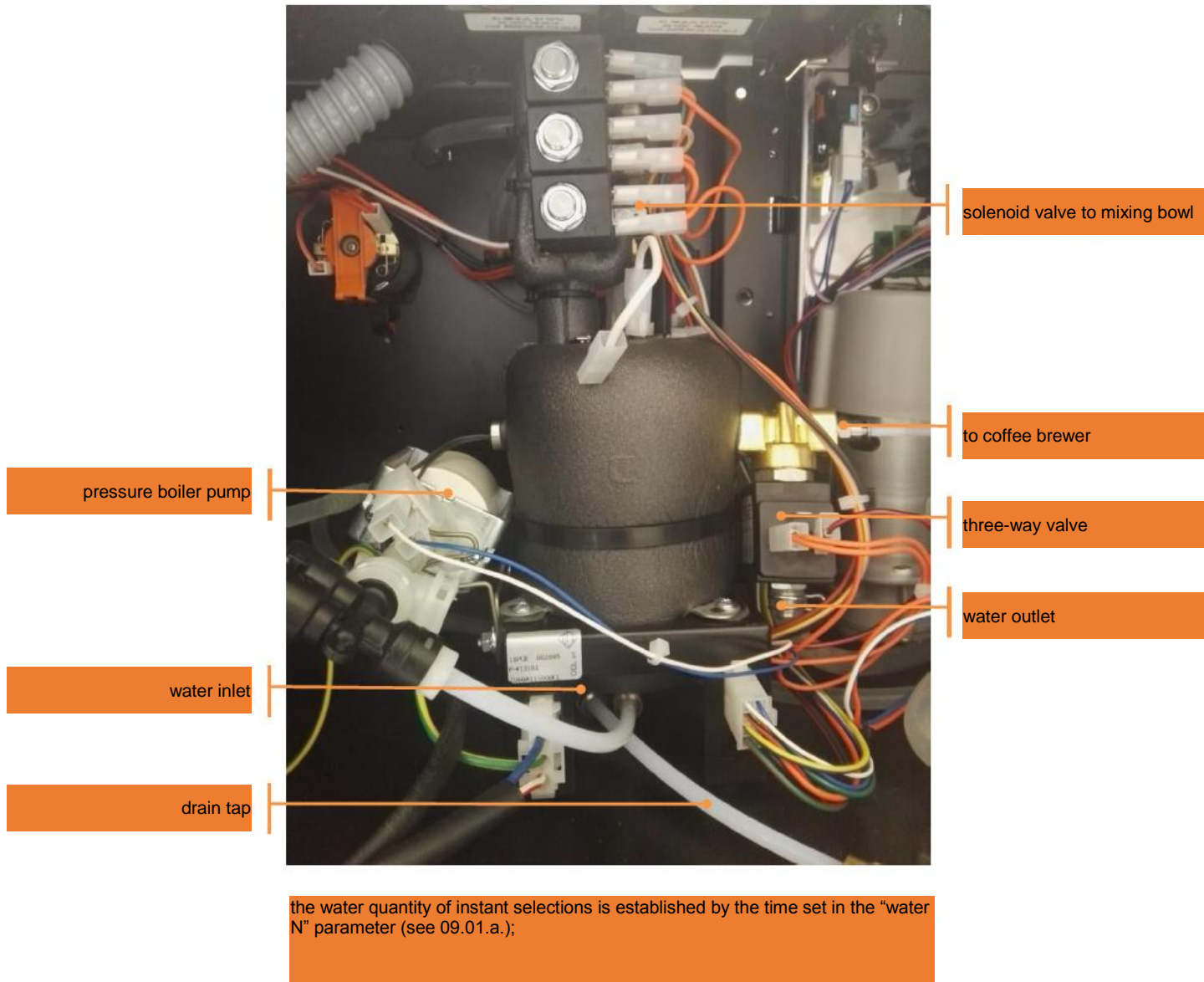

COFFEE BEANS CANISTER

- 01 canister lid with key
- 02 actuator piston for canister presence microswitch
- 03 grinder cover
- 04 coffee beans hopper
- 05 coffee beans hopper adapter
- 06 coffee beans hopper stopper

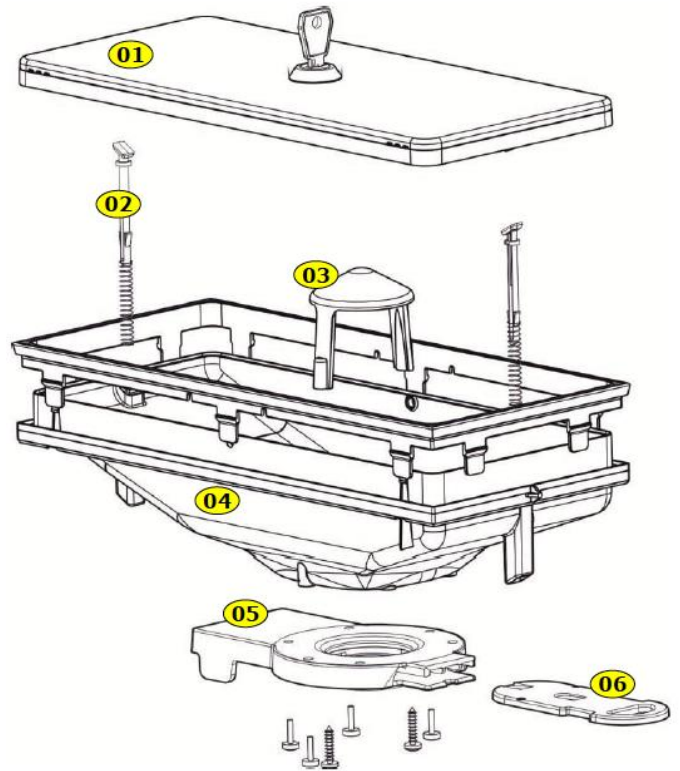

INGREDIENT CANISTER 110 LEFT

- 07 canister lid with key
- 08 wheel pin fork
- 09 plastic wheel
- 10 actuator piston for canister presence microswitch
- 11 product agitator left
- 12 product agitator small left
- 13 rear bush
- 14 spiral 9 or 18
- 15 wheel pin
- 16 ingredient canister

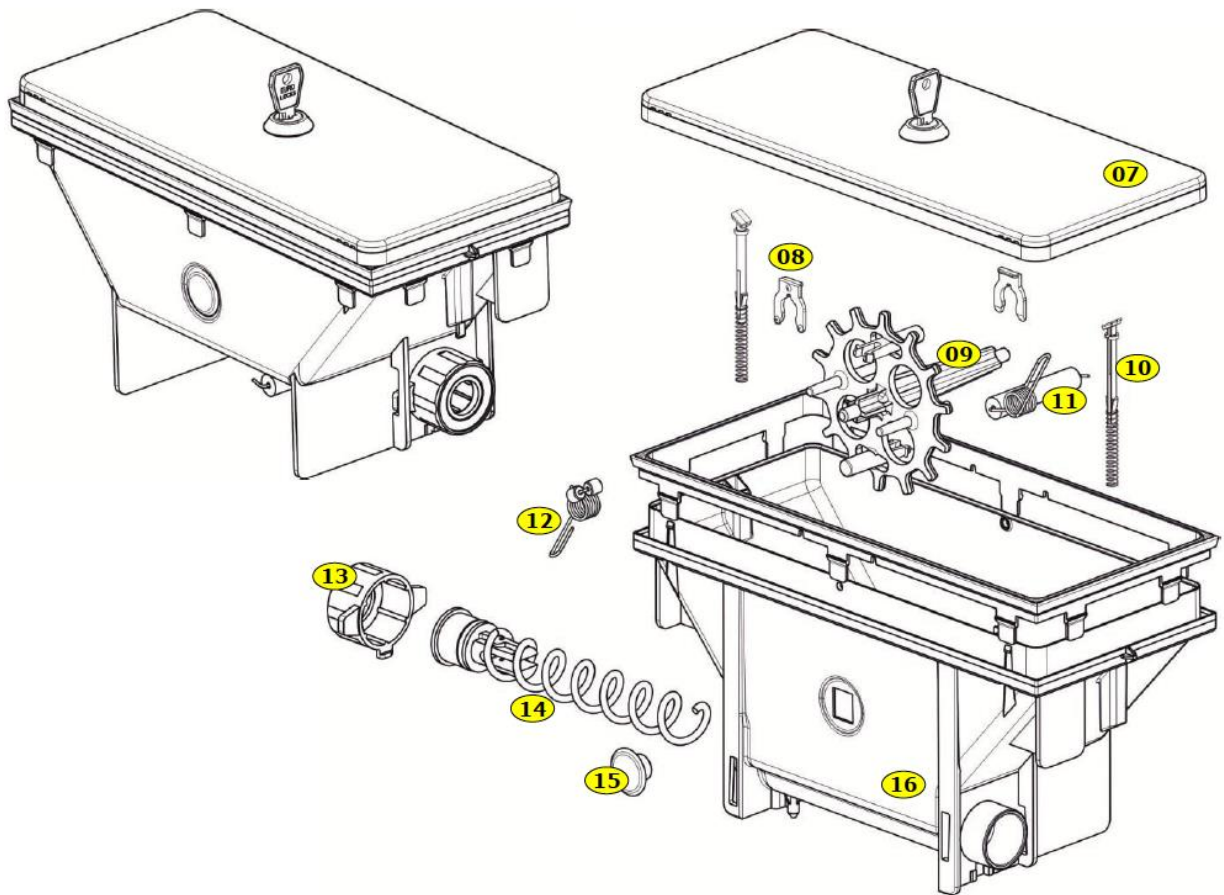

05.36. electronics	<p>The CPU board is intended to govern the machine operation. It is the place of location of machine programs and it is secured to the frame by means of four board supports.</p> <p>The temperature probe cable is separated from the machine wiring to avoid hampering the removal of the probe; the boiler led will turn on whenever you activate the boiler heating element.</p>	
--------------------	--	--

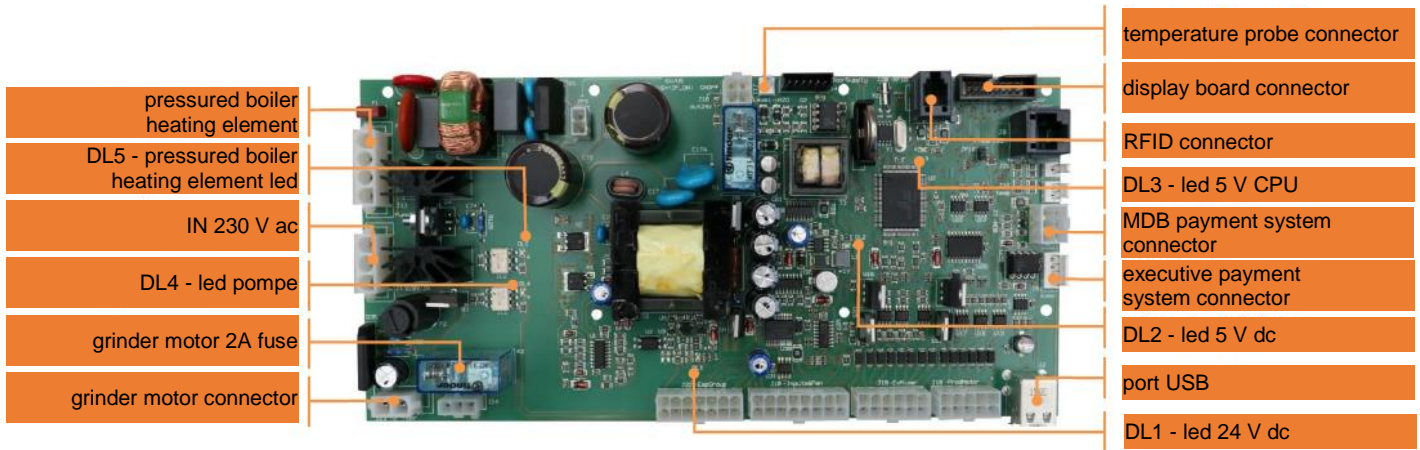

05.36.b. display board	<p>The display board, placed inside the door, collects the signals of the selection keyboard and allows the messages visualization through the display; it's connected with the CPU by a flat cable for the signals exchanging; the inner programming button, it's installed on the printed circuit board; the display board also illuminate the keyboard.</p>	
------------------------	--	--





05.36.c. Bluetooth-module	<p>The optional bluetooth module is positioned on the GPU board, allows a normal user to select a drink through a special app on the smartfone or combine the products to obtain a personalized beverage; the advanced user can, by means of an access pin, access some distributor software functions and adjust the software parameters, download the audit data and the refilling options of the products.</p>	
---------------------------	---	--

App UI	<p>The User can run an Application on his/her own device (i.e. SmartPhone, Tablet, etc), named coffee perfect app.</p>	
--------	--	--



05.36.d. RFID	<p>The RFID card is a hardware option that can equip the machine; it enables the operator to program the product decounters and/or it can be used as a payment system.</p>	
---------------	--	--

<p>05.36.e. modem</p>	<p>A modem, connected with the CPU board by means of a phone cable and supplied by 24 V, provides for connection with a remote operator to send/receive data and information on the machine states by means of an aerial placed inside the door.</p>	
-----------------------	--	--

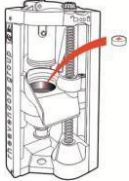

<p>06. preliminary actions</p>		
<p>06.01 handling</p>	<p>The vending machine may be transported, handled and positioned by skilled and trained personnel only; while handling, never overturn the machine; observe the orientation arrows on the package.</p>	
	<p style="text-align: center;">Attention</p> <p>Handle the machine carefully to prevent the authorised personnel from being injured; considering the weight and overall dimensions of the vending machine, it is recommended to use a truck at low speed.</p>	
<p>06.02. unpacking</p>	<ul style="list-style-type: none"> ▪ approach the packed vending machine to its work position; ▪ cut the two plastic belts; ▪ lift the external package; ▪ extract the protection bag up; ▪ lift the vending machine and arrange it on the work surface; 	
 	<p style="text-align: center;">attention</p> <p>The materials composing the package shall never be left within the reach of people from outside, in particular of children, because they represent a potential source of danger. Only specialised companies may be charged to provide for the disposal of package components.</p>	
<p>06.03. positioning</p>	<p>The vending machine shall be arranged for work in a sheltered room by using a support suitable for the weight of the machine (see 03.02.); its distance from the walls shall provide for good air circulation and easy access.</p>	
	<p style="text-align: center;">aAny inclination of the surface shall not exceed 2°.</p> <p>It is recommended to arrange an easily cleanable impermeable protection beneath the vending machine to collect any accidental product fall.</p>	
<p>06.04. preparation</p>	<p>When the machine is in its final working position:</p> <ul style="list-style-type: none"> ▪ cut the clamp securing the door key to the liquid recovery tray gridded cover or to the flap support for cups ▪ insert it into the lock (see 05.05.), rotate it and open the door ▪ remove the envelope of documents and labels ▪ take the power supply cable and the water union; the water union can be used for water connection with the network ▪ lift the machine cover and remove the guards intended to fasten product containers for transport ▪ insert the labels by observing the order of selections determined by the machine configuration (see 04.02.) 	

<p>07. connections</p>		
<p>07.01. water</p>	<p>Make sure that the water used to supply the vending machine has all proper features for human consumption.</p> <p>Make sure that there is no sign of impurity and check the degree of hardness; if necessary, contact an analysis lab.</p> <p>If necessary, use a softening filter and replace the cartridge at regular intervals, in observance of the manufacturer's instructions, to preserve the machine components.</p>	
	<p>Make sure that the network pressure is the one preset for the machine (see 03.03.); use a pump or a reducer in case of non-compliance; it is recommended to install a tap to detach the machine from the network; connection shall occur by means of:</p> <ul style="list-style-type: none"> ▪ new tube; ▪ of type-approved material for food use; ▪ compliant with "IEC 61770 Electric appliances connected to the water mains"; ▪ it can support the working pressure; <p>if the tube is not supplied with the machine or in case of replacement use tubes featured as above only.</p> <p>For the drinkability features of "waters intended for human consumption" refer to the following Internet address:</p> <p style="text-align: center;">http://eur-lex.europa.eu/ directive 98/83/EC of 03/11/1998</p>	
<p>07.02. energy</p>	<p>Observe the rules on connections with the electric network, in particular on grounding; connect the machine permanently without using any reduction, adaptor, multiple socket or extension; use the network connection cable supplied with the vending machine only; it is recommended to install a switch detaching the machine from the network.</p> <p>It is recommended to install a differential current device operating below 30 mA, detaching the machine from the mains and promptly tripping in case of improper electric input in order to considerably reduce the risks arising out of any short-circuit.</p>	
	<p style="text-align: center;"><u>attention</u></p> <p>Check the power plant capacity to supply the power required by the machine (see 03.03) and the observance of the rules in force; strictly refer to the data of the serial number label (see 02.03.).</p> <p>For a correct and safe configuration of the electric power supply installation refer to the following Internet address, if necessary.</p> <p style="text-align: center;">http://eur-lex.europa.eu/ directive 2006/95/EC of 12/12/2006</p>	

<p>08. installation and first power on</p>		
<p>08.01. introduction</p>	<p>After having unpacked the vending machine, arranged it firmly in the work place and connected hydraulically and electrically, carry out some actions to operate it.</p> <p>Wash hands thoroughly with water and soap before handling the machine and the products; only use potable water to clean the components.</p>	
<p>08.02. activity</p>	<p>Open the door, power on the main switch of the machine (see 05.08.).</p>	
	<p style="text-align: center;">attention</p> <p>Arrange a cup beneath the nozzles, insert and rotate the service key into the door switch (see 05.12.).</p>	
	<p style="text-align: center;">attention</p> <p>The vending machine is supplied and running to all effects; the mobile parts of the coffee brewer will be handled; act extremely carefully.</p>	
	<p>At the end of assembly and final testing, the water used for testing is discharged from the machine; at the first power-on at the station, all circuits must be filled in before any other action; for this reason, the machine will automatically load water.</p>	<p style="text-align: center;">Starting up VMC...</p>
	<p>The vending machine executes a diagnostic cycle for loading and heating waters; the warning messages for the progress of these phases appear on the display.</p>	<p style="text-align: center;">Starting up VMC...</p> <p style="text-align: center;">refilling water wait</p> <p style="text-align: center;">...</p> <p style="text-align: center;">INSTALLATION</p>
	<p>Make sure that the machine is hydraulically supplied and that the drip tray is inserted; while following the display messages, press "10" to carry out the first installation.</p>	<p style="text-align: center;">Water OK ? 10= START</p> <p style="text-align: center;">driptray inside 10= START</p>
	<p>The display shows:</p>	<p style="text-align: center;">first install. starts automat</p> <p style="text-align: center;">Auto-Reset</p>
	<p>Wait for water to come out of the product nozzles for some seconds; the flow will automatically stop after dispensing all necessary water and the display will show:</p>	<p style="text-align: center;">refilling water wait</p>
	<p>The pressure boiler or the instant boiler water starts heating to achieve the temperature setpoint (see 09.01.e.);</p>	<p style="text-align: center;">wait temperature</p>
	<p>At the end of this phase, ca. 3 minutes later, the display will show the standby messages</p>	<p style="text-align: center;">Automat machine ready</p> <p style="text-align: center;">Rheavendors</p> <p style="text-align: center;">place your cup</p>

<p>08.03. washing</p>	<p>Transportation, storage and installation conditions can not provide for immediate utilisation of the vending machine and it is recommended to perform a complete wash cycle before using the vending machine</p> <p>Press the programming button (see 05.13.); the display shows alternatively the messages.</p>	
	<p style="text-align: center;">attention</p> <p>The vending machine is supplied and running to all effects; the mobile parts of the coffee brewer will be handled; act extremely carefully.</p> <p>Arrange a cup beneath the nozzles; the machine will dispense a pre-fixed water quantity for each wash cycle.</p> <p>Press “4” to enable the wash cycle of the water circuit (boiler, tubes, mixing bowls, ...).</p>	
	<p>Follow the display instructions that require the operator to must be sure that the drip tray is empty and the machine is hydraulically connected.</p>	<p>drip tray empty? 10= START</p> <p>water OK ? 10= START</p>
	<p>The display shows</p> <ul style="list-style-type: none"> ▪ in the espresso version, key “1” will dispense water through the coffee brewer; selections “2” and “3” will do it in the two mixing bowls for instant products; key “4” in the hot water outlet hole to the cup; ▪ in the instant version, keys “1”, “2” and “3” will dispense water into the three mixing bowls for instant products; key “4” in the hot water outlet hole to the cup; <p>Repeat the operation for some times to rinse the whole water circuit of the machine; during the wash cycles, the display will show the circuit that is being washed.</p> <p>In the cleaning menu, there are two other options.</p>	<p>CLEANING 1-2-3-4 5=steam 8=hc.</p> <p>CLEANING 1-2-3-4</p>
<p>key „5“</p>	<p>To clean the hydraulic circuits of the CAPPUCCINO-R if this module is connected with the machine.</p>	<p>CLEANING 1-2-3-4 5=steam 8=hc.</p>
<p>key „8“</p>	<p>Enables a special wash cycle to sanitise the coffee brewer by using specific cleaning products in tabs (or in powder).</p>	<p>CLEANING 1-2-3-4 5=steam 8=hc.</p>
 	<p>After having positioned the cup beneath the dispensing nozzles, press key “8=hc.”; the machine performs two washing with water; the brewing chamber opens; the display shows.</p> <p>Put a tab in the coffee brewer chamber and press “10”. The chamber closes while keeping the tab brewing for the time set in “09.01.u. Variflex / tab dissolve pause sec”; the time counter for the tablet dissolution begins to decrease up to arrive at 0 min.; follow the display instruction and wait for the wash cycle to automatically come to an end. After the chamber is emptied and it starts a six-rinsing cycle.</p> <p style="text-align: center;">attention</p> <p>App. 100 cc. water will be dispensed for each one of the six wash cycles.</p> <p>At the end of the sanitary wash cycle of the coffee brewer, the machine will also wash the mixing bowls and the direct water circuits; for this reason, make sure that at least a couple of cups can be placed beneath the product nozzles.</p> <p>if this cycle should be interrupted (sudden power failure, ...), the procedure will restart from the initial step of this wash cycle as soon as operation is restored.</p>	<p>cleaning active</p> <p>put pastille and push P10=START</p> <p>tab dissolve >:>>> 1:15 min</p> <p>cleaning brewer 6 X 1/6</p>

	Power off the vending machine by means of the service key; arrange it in its support (see 05.12.); power off the main switch at the back of the machine (see 05.08.).	
08.04.	<p>08.04. prepare a chlorine-based anti-bacterial sanitising solution by observing the instructions supplied with the product; remove and immerse the following into the solution: the product canisters you have disassembled, the trays of mixers, their fans and the silicone tubes intended to dispense products; the time necessary to sanitise is specified by the anti-bacterial product package; at the end, remove all the parts you have sanitised from the solution, dry them carefully by using clean cloths and reassemble them into the machine; rotate the baffles of the product chutes of instant canisters to close them and load the canisters with reference to the machine configuration (see 04.) and to the canister labels; fill in the coffee hopper with coffee beans; close the canisters and the coffee hopper with their upper covers. Rotate the baffles of the product chutes (see 05.22.) to open them and pull the orange blade of the coffee hopper; (see also 12.).</p> <p>To clean and treat food products properly, refer to the content of the following Internet address:</p> <p style="text-align: center;">http://eur-lex.europa.eu// regulation 2004/852/EC of 29/04/2004</p> <p>Lower down the cover and close the door by means of the lock key (see 05.05.) and place it in a safe place;</p>	
08.05.	Power on the machine by means of the main switch; the display 08.05. will show in sequence following messages:	switching on... please wait
	Till the water temperature of the instant boiler or the pressure boiler is suitable for the value set in the memory (by default):	wait temperature
	At the end of this phase intended to heat water in the pressure boiler, the vending machine is ready to dispense on a free basis and the display will alternatively show some stand-by messages::	place your cup

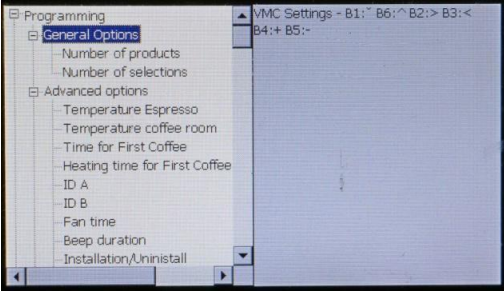
<p>09. programming</p>	<p>The vending machine is programmed by means of parameters considered standard for the specific configuration required; values forming the composition of recipes – written in the board memories – enable the user to dispense drinks without requiring the installer to set up special programmes; to modify these parameters to adapt the drinks you have produced, refer to the following; at the end of the chapter (see 09.07.), a summary table may help the user trace back all the programming items; to access the programming mode, open the front door of the machine and use the service key in the safety switch.</p>	
	<p style="text-align: center;">attention</p> <p>The vending machine is supplied and running to all effects in this mode of operation; act extremely carefully.</p>	
<p>access the programming mode</p>	<p>Press the “PROG” key (see 05.13.), the display shows:</p> 	
<p>quit the programming mode</p>	<p>After having programmed, press “1” and then the key “PROG” to go back to the usual operation of the vending machine and to store all changes you have made; the display will show:</p>	<p>END PROGRAMMING wait</p>

Programming

09.01. Programmiermenü

A General options	
1	number of products
2	number of selections
B Advanced options	
1	Temperature espresso
2	Temperature coffee chamber
3	Time for first coffee
4	Heating time for first coffee
5	ID A
6	ID B
7	Fant time
8	Beep duration
9	Installation/Unistallation
10	Piston position of espresso group
11	Language
C Payment system	
1	Payment type
2	Number decimals
3	Banknote acceptance
4	Price 2 usage
5	Price 3 usage
6	Parallel
	Coin A

	Coin J
7	RFID
	Maximum RFID credit
	Coin A with RFID available
	Coin A with RFID not available

	Coin P with RFID available
	Coin P with RFID not available
8	MDB
	Change enabled
	Maximum credit
	Maximum change
	Vending type
	Token value
	Coin enable table
	Coin A accept with change
	Coin A accept No change

	Coin P accept with change
	Coin P accept No change
	Enable escrow
	Manual coin eject
	Tubes status
	C ashless recharge disabled
9	EVA DTS
	ID101
	ID104
	ID106
	EVA-DTS adress
	EVA-DTS port mode

Programming

D	Selections		
		1	Sel 1 - C AFFE C ORTO
		2	Selection type
		3	Espresso group identifier
		4	Espresso before/after
		5	Preinfusion
		6	Reps for RFID jug
		7	Stop delivery for RFID jug
		8	Prices
			Price 1
			Price 2
			Price 3
			Price 4
		9	Ignitions
			Device [1] – Espresso
			Duration [1]
			Delay [1]
			Grinder time [1]
			Pastille decompression
		
			Sel.. 45 - selection 45
E	Free Vend		
		1	Sel 1 - CAFFE CORTO
		
			Sel 12 - Selection 12
		2	Freevend mode for X hours
F	Rinsing/Washing		
		1	Mixer 1
			Mixer 2
			Mixer 3
		2	Group washing (with pastille)
G	Date and time		
		1	Year
			Month
			Day
			Hour
			Minute
			Second
		2	Daylight saving (summertime)
		3	Save Date and Time
H	Decounters		
		1	Dec limit 1 - water filter [dsec]
			Dec value 1
			Reset Dec 1
		
			Dec limit 10 - product 6 [dsec]
			Dec value 10
			Reset Dec 10

Programming

I	Data audit		
		1	Total cups
			Partial cups
			Total sales
			Partial sales
			Total cash coin sales
			Partial cash coin sales
			Total cashless sales
			Partial cashless sales
			Total RFID sales
			Partial RFID sales
			Total free vend
			Total Test vend
			Totals for selections
			Total Sel 1
		
			Total Sel 12
			Partials for selections
			Partial Sel 1
		
			Partial Sel 12
			Teil-Reset

L	Timetables		
		1	Energy saving bands
			On hour – Monday
			On minute – Monday
			Off hour - Monday
			Off minute - Monday
		
			On hour - Sunday
			On minute - Sunday
			Off hour - Sunday
			Off minute - Sunday
		2	Happy Hour
			Start hour – 1
			Start minute –1
			End hour - 1
			End minute - 1
		
			Start hour - 3
			Start minute - 3
			End hour - 3
			End minute - 3
			Washing machine hour
			Washing machine minute
			Washing milker hour
			Washing milker minute

M	Error Log		
		1	Reset error log

Programming

N	Various		
		1	Show debug info
		2	Firmware (software) versions
		3	Enable H2O filter reset
		4	Drip tray presence check
		5	Conversion factors for products
			Conversion factor product 1
		
			Conversion factor product
		6	Product motor calibration
			Calibration product motor 1
		
			Calibration product motor 6
		7	Milker
			Steam temperature
			Rinsing period
			Rinse delay
			Delayed rinse
			Milk instant product
		8	Grinder auto-adjust
		9	Grinder 1 calibration
		10	Modem test
		11	Reset BLE keys
		12	Get voltage
		13	Energy consumption

10. parameters		
10.01. limits	The table is intended to list the minimum and maximum values you can assign to programmable variables:	

m.u	from	to
-----	------	----

exp coffee water	n.	0	250
------------------	----	---	-----

0 = no espresso;

Product	sec.	0	20
product start delay	sec.	0	20
number of product pauses	n.	0	2
water time	sec.	0	20
water start delay	sec.	0	20
water flux		->	->
mixer	sec.	0	20
mixer start delay	sec.	0	20
mixer speed		->	->

0 = no product;
0 = no delay;
0 = no pause;
0 = no water;
0 = no delay;
low, medium, high
0 = no mixer;
0 = no delay;
low, medium, high

temperature boiler	°C	0	95
temperature pressure boiler	°C	0	105
first coffee temperature	°C	0	105
first coffee time	Min.	0	20
heater temperature	Min.	0	40



product decounter	sec.	0	6,000
machine code A e B	n.	0	65,535
message number	n.	0	7
fan delay	min.	0	180
beep time	sec.	0	1,5
number of decimals	n.	0	3
coin A ÷ J	n.	0	65,000
prices 1 ÷ 12	n.	0	65,000
tuning pump	->	->	->
tuning motor	->	->	->
tuning grinder	->	->	->

+/- 30%
+/- 30%
+/- 30%



<p>11. solution of problems</p>	<p>Any event that may occur during the operation of a machine may totally or partially compromise its functionality.</p> <p>To help the operator restore the normal functionality of the vending machine, the display shows an error code as an abbreviation that identifies the malfunction and helps the operator find the faulty device.</p> <p>The content of this chapter is intended to collect, expand and comment upon these abbreviations, which are forcedly concise, to facilitate the solution of the failure.</p> <p>Please note::</p>	
<p>1.</p>	<p>in the machine, the error may be signalled with or without a suffix that – if present – is intended to specify the meaning better; however, the number on the display identifies for sure the devices, assemblies and functions in question.</p>	
<p>2.</p>	<p>in the following table:</p> <ul style="list-style-type: none"> ▪ the first column shows the machine number; any variant is shown with the detail letters for more specification ▪ the second shows the machine district or function affected by the event ▪ the third one contains a comment, the purpose of which is to help find a solution; these notes are surely not exhaustive because a malfunction may have several causes or be originated by an ensemble of factors, but they any way give some hints on how to proceed 	
<p>3.</p>	<p>Not all malfunctions are signalled by an error message since the latter is generated by electric controls that are not made available in all machine districts.</p>	
<p>4.</p>	<p>This document is meant only for the technicians who are – at least briefly - familiar with the technologies, machines, devices and names generally used in the vending field; the wiring diagrams supplied with the machine are absolutely necessary to understand and solve the events described herein.</p>	
	<p style="text-align: center;"><u>attention</u></p> <p>While performing the actions necessary to restore the machine functions, act with the utmost caution and strictly observe the safety instructions for operators and users.</p> <p>See also: Technical Information no. 138 → error messages</p>	

OFF 2	<u>payment system</u>	
	<u>protocol</u>	
OFF 2 E OFF 2 M OFF 2 P	executive MDB parallel	No communication between the payment system and the vending machine CPU; it might be caused by improper power supply, false programming or payment system malfunction.
OFF 3	<u>waste water bucket</u>	
		The switch controlling the liquid level in the bucket has tripped because operated by the floater; make sure that it is properly positioned after the bucket has been emptied.
OFF 5	<u>EAROM</u>	
		Those integrated in the CPU board fail to operate properly.
OFF 6	<u>water supply</u>	
OFF 6 A	boiler	Boiler or air break filling time too long; the water supply might be totally.
OFF 6 C	air break	Lacking, its pressure might be not enough or some obstacle might slow down the regular water flow (filter grilled cover, load pipes either choked or clogged); the water inlet solenoid valve safety has tripped.
OFF 6 B OFF 6 D	boiler air break	The boiler or the air break circuit has been refilled with water, but no drink has been dispensed; the supply circuit might have a leakage.
OFF 6 F	boiler	During the first installation phase, water inlet error in the machine; after having opened the water inlet solenoid valve, the CPU waits for water to wet the boiler level probes within a well-defined time interval; if this does not occur, error 6F is triggered.
OFF 6 G	pressure boiler	During the first installation phase, water inlet error in the machine; after having opened the water inlet solenoid valve and activated the pump, the volumetric counter shall send the CPU a sequence of pulses to give evidence that water is flowing; if this does not occur, error 6G is triggered.
OFF 7	<u>espresso circuit</u>	
OFF 7 A	pompa espresso	The power-on time of the espresso circuit pump has exceeded the limit; the water flow has encountered more resistance than usual and the pulses produced by the volumetric counter have required a time interval deemed to be too long for a dispensing cycle within proper limits; also check the grinding amount and degree of coffee beans poured into the coffee brewer chamber.
OFF 7 C	brewing chamber	During the brew phase, the chamber has moved down, beyond the safety position, because of pressure.
OFF 8	<u>coffee brewer</u>	
OFF 8 A	piston	Error in the motor of the coffee brewer due to power failure or wrong energy supply, error in detecting the rotation.
OFF 8 B	presence	The machine fails to recognise the presence of the coffee brewer; the physical presence of the Variflex® coffee brewer is controlled by the vending machine to inhibit the dispensing of selections including coffee beans (if the coffee brewer is not acknowledged to be in position). Notes: it might happen that OFF 8 is displayed with capital or small letters, other than those specified above (A, B); these messages - always hinting at an error caused by the coffee brewer or by its motor - have a highly technical meaning that would be superfluous and misleading to specify in details.
OFF 9	<u>coffee beans</u>	
		As soon as the grinding phase has been completed, the brewing chamber of the Variflex® coffee brewer is moved up, to the upper piston, to compress ground coffee; if the motor fails to encounter the expected resistance during this phase, this means that the ground coffee quantity is less than required or completely lacking.



OFF 10	<u>EAROM</u>	Stored data are not consistent (reading or writing error) and the overall operation of the vending machine may be otherwise than expected.
OFF 14	<u>water inlet</u>	
OFF 14 A	boiler	if water is not reloaded after six dispensing cycles, error 14 is triggered.
OFF 14 B	pressure boiler	Even a water inlet pressure value other than the pre-set one, may cause this error, thus filling in the pressure boiler or the instant boiler in excess and providing for a number of dispensing cycles higher than the pre-set one; if selections are dispensed with a limited water quantity, the error is more likely to occur.
OFF 16	<u>programming keyboard</u>	The programming keyboard inside the machine has a short-circuited key or it has been pressed too long; if pressed too long, the manual release button of cups turrets may cause this error.
OFF 17	<u>keyboards</u>	
OFF 17 A	selection	A button appears as if it were constantly pressed.
OFF 24	<u>power supply unit</u>	
OFF 24 A	24 V dc	The actual 24 V dc voltage value is higher than the tolerated one.
OFF 24 B	24 V dc	The measured 24 V dc voltage value is below the admitted threshold or totally absent, e.g. because a fuse has tripped; find out and remove the causes that have produced this error before powering on the machine again.
OFF 31	<u>espresso coffee water</u>	
OFF 31 A	temperature	The pressure boiler water temperature is higher than the programmed value;.
OFF 31 B	temperature	Water fails to achieve the set temperature.
OFF 31 C	pressure boiler probe	The temperature probe is interrupted or its electric connector is detached.
OFF 31 D	time	The temperature fails to achieve the programmed value within the admitted time limit.
	<u>coffee brewer heater</u>	
OFF 32 A	temperature	The coffee brewer temperature is higher than the set value.
OFF 32 B	temperature	The c coffee brewer temperature is lower than the programmed one.
OFF 32 C	temperature	The coffee brewer temperature probe is faulty.
OFF 33 A, B, C	<u>instant-water</u>	They have the same meaning of errors 31A, B e C, but referred to I machines.
OFF 77	<u>CPU</u>	The "clock" function is not properly performed; the buffer battery might be low; after having restored the function, carefully check the clock-related machine functions: happy hour, time bands... .. that might have been compromised by the lack of time references.
OFF 380	<u>MDB change giver</u>	
OFF 80 4	pipes	A pipe sensor is not properly working.
OFF 80 6	validator	Validator not inserted or disconnected.
OFF 80 7	pipe	A coin pipe is not properly working.
OFF 80 8	memory	ROM with reading/writing error.
OFF 80 C	coin	Coin locked in the acceptance path.
OFF 80 D	coin	Attempt at fraud and coin removal.

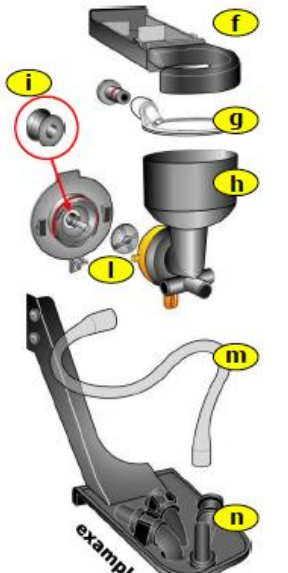
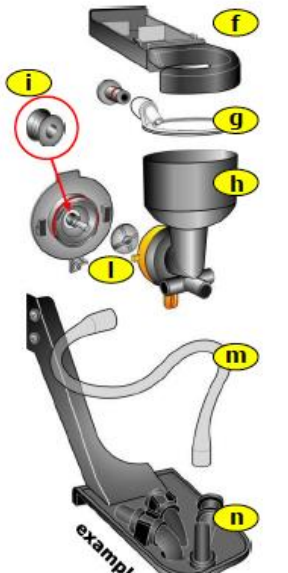
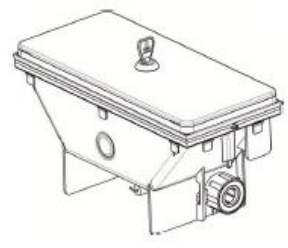

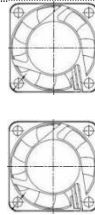
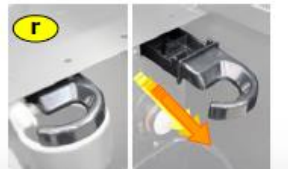



<p>12. maintenance</p>	<p>The Eleganza-series vending machine requires no special maintenance procedure to do its job; however, if you provide for careful and frequent cleaning, this may help the machine keep its performance constant, prevent failures and ensure the high quality of dispensed drinks; the frequency of cleaning operations largely depends upon the number of dispensing cycles and the hardness of water in use (use a softener system) and it shall be adjusted to the working conditions of the vending machine.</p> <p>The actions described are intended to prevent the bacterial growth in the machine areas directly in contact with foodstuffs and to keep the parts conveying drink-composing products clean; after having disassembled the parts of the machine listed here below, use plenty of lukewarm water to remove any residue that might build up.</p> <p>The support of a bacterial static or bactericidal solution may strengthen a deep cleaning action, provided it is compatible with human health and the supply of foodstuffs; reassemble all the parts you have cleaned after having dried them by means of a clean piece of cloth.</p> <p>Refer to the content of the Internet address:</p> <p style="text-align: center;">http://ec.europa.eu/food/safety/biosafety/</p> <p>This site is intended to supply the European Parliament recommendations for properly and safely processing foodstuffs; consult also the 2004/852/EC European Community regulation</p> <p style="text-align: center;">http://eur-lex.europa.eu/legal-content/EN/TXT/?uri=URISERV:f84001</p> <p>before accessing the machine for each maintenance operation, it is recommended to warn the users by means of boards properly positioned that it is forbidden to approach the vending machine and to use it.</p>	
	<p style="text-align: center;"><u>Attention</u></p> <p style="text-align: center;"><u>Never wash the machine by using water jets; wash hands thoroughly with water and soap before handling the machine and the products.</u></p> <p style="text-align: center;"><u>Only use potable water.</u></p> <p style="text-align: center;"><u>All components must only be cleaned with warm running water.</u></p>	

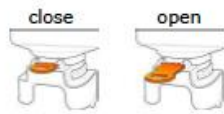
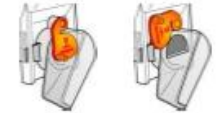
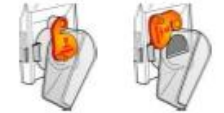

<p>12.01. weekly</p>	<p>Power off the machine; detach the power supply cable and carefully make sure that there is no sign of wear; carefully check the stability and efficiency of the internal connections of the mains supply.</p>	
<p>drip tray</p>	<p>Extract the drip tray (a), remove the upper grilled cover and wash with plenty of water; open the door and clean the drip tray housing and the nozzle holder spout inside the machine (e).</p>	
<p>grounds container</p>	<p>After having opened the door and removed the drip tray, pull the right side of the drawer forward and remove it; observe the position of the water inlet tube of the brewer.</p>	
	<p style="text-align: center;">attention</p> <p style="text-align: center;">The residual coffee grounds shall be disposed of in observance of the sanitary obligations in force in the country.</p>	
<p>product chutes</p>	<p>Turn the baffles of product chutes (c) into a close-position, remove them from the canisters and wash them with plenty of lukewarm water (product chutes are plug-in secured).</p>	
<p>dispensing system</p>	<p>Turn the fixing levers of mixing bowls clockwise (d), remove the product nozzles from the holder by releasing them, pull the mixing bowl and the dust extraction ring; wash the assembly of disassembled parts with plenty of lukewarm water.</p>	
<p>inner side of the machine</p>	<p>Remove all residues from the internal surfaces of the machine and the door, above all in the proximity of the cup station and clean with a piece of wet cloth.</p> <p>Dry the parts carefully and re-mount them on the machine.</p> <p>After opening the door, re-connect the supply cable and power on the main switch.</p> <p>Use the service key;</p>	
	<p style="text-align: center;">attention</p> <p style="text-align: center;">Act extremely carefully.</p> <p>The vending machine is supplied and running to all effects; the mobile parts of the coffee brewer will be handled; act extremely carefully.</p> <p>Perform some wash cycles of the hydraulic machine circuits (see 08.03.).</p> <p>Remove the service key, put it into its housing, close the door.</p>	
<p>external body</p>	<p>Clean outside the machine by using a piece of non-abrasive cloth, dampened with lukewarm water; use a neutral, non-foamy detergent, only if necessary.</p>	
	<p style="text-align: center;">attention</p> <p>Use neutral detergent products only; never use abrasive cloths, steel sponges, aggressive or foamy detergents and other solvents, hot water and acids.</p>	

<p>12.02. monthly</p>	<p>Besides fulfilling the tasks already specified by chapter 12.01. weekly, it is also recommended to act in the following districts:</p>	
<p>dispensing system</p>	<p>Disassemble all components of the dispensing system:</p> <ul style="list-style-type: none"> ▪ extraction drawer (f) ▪ water dispensing ring (g) ▪ mixing bowl (h) ▪ mixer (l) ▪ dispensing tubes (m) ▪ product dispensing nozzle holder (n) <p>Extract the mixer fan just by pulling it; check the wear state of the w ring (i) sheathing the mixer motor shaft; wash the assembly of disassembled parts with plenty of lukewarm water.</p>	
<p>products canister</p>	<p>Remove the product canisters (o) by lifting them in the front and by pulling them; remove the cover and empty the product residue.</p> <p>Turn the baffles of product chutes into a close-position; remove them from the canisters and wash them with plenty of lukewarm water, as it is described by chapter 12.01. weekly.</p> <p>At the back of the product canister turn the black ring nut clockwise and remove it; extract the worm screw by pulling the black bush; to facilitate disassembly, push the stirring wheel in the correct direction.</p>	
<p>coffee brewer</p>	<p>Lift the two fastening clips (one for each side) from the inside of the product canister and remove the two red plugs from the outside; remove the stirring wheel; wash the disassembled parts with plenty of lukewarm water.</p>	
<p>environmental and powder aspirators</p>	<p>The whole coffee brewer can be cleaned and washed with running water since it has no component that may be damaged; to extract the coffee brewer, first remove the coffee dispensing tube from the nozzle holder, release the carter (p) by pressing on each side and by pulling it to the outside, remove the ground grey conveyor just by pulling it, remove the coffee brewer (q) by pressing the orange release button, by lifting it slightly and by pulling it.</p>	
	<p>Carefully check that the rotors of the two aspirators on the rear panel of the vending machine can freely rotate without any hindrance or stoppage; make sure that the corrugated tube for connection between the powder aspirator and the extraction drawer (r) is clean and free of any product deposit.</p>	

<p>12.03. yearly</p>	<p>Besides fulfilling the tasks already specified by chapters 12.01. weekly and 12.02. monthly, it is also recommended to act in the following districts.</p>	
<p>dispensing system</p>	<p>Replace the gasket at the base of the mixing bowl of the mixer; remove the mixer motor fan by pulling it; replace the gasket of the mixer motor shaft.</p>	
<p>silicone tubes</p>	<p>Make sure that the water transport tubes are intact and that they have kept their transparency, replace them, if necessary.</p>	
<p>boiler</p>	<p>Empty the boiler by means of a drain pipe; extract it from the machine, remove the cover and wash the tank by removing any solid residue that may have built up at the bottom. Remove any calcareous deposit from active elements: temperature probe, heating element, level probes, the shafts of rotary pumps.</p>	
<p>in E machines coffee brewer</p>	<ul style="list-style-type: none"> ▪ replace the three sealing rings (s) of the compression chamber and lower piston guide ▪ replace the upper and lower filters (t) ▪ check the state of the compression chamber 	
<p>pressure boiler</p>	<p>Disassemble the pressure boiler; separate the pressure boiler from the solenoid valves block (u) and check the seal o-ring; clean the instant and espresso outlet water circuits; check the third way of the espresso valve drain by removing any trace of residue (v);</p>	
<p>air break</p>	<p>empty and clean the air break tank (z); carefully check the micro switch functionality operated by the floater rod and make sure that it can freely slide without any hindrance;</p>	
<p>12.04. out of order</p>	<p>if the vending machine should be inactive for a long period, please act as follows:</p>	
<p>temporary</p>	<ul style="list-style-type: none"> ▪ in E machines, perform the uninstall cycle ▪ in I machines, set the boiler water temperature to zero ▪ detach the water and energy supply ▪ in I machines, empty the boiler (see 13.20.) ▪ empty the liquid waste tray and the internal water tank ▪ empty and clean the product canisters ▪ clean the internal and external surfaces by using a wet piece of cloth ▪ cover the machine by means of a cloth ▪ store it in a sheltered place, at a temperature not below 5 °C, at a relative humidity not above 80% 	
<p>definitive</p> 	<p>If you should definitively set the vending machine out of commission and provide for the disposal of some parts thereof, after having carried out the operations above, disassemble the vending machine by separating every single component and subdividing the parts according to the nature of materials; the applied symbol means that the components of the vending machine shall be not processed as home rubbish, but delivered to the collection points capable of recycling electric and electronic equipment; refer to the 2012/19/EU Directive and to the relative rules.</p> <p>The complete text of the European directive about this specific subject-matter is made available on the Internet site:</p> <p style="text-align: center;">http://eur-lex.europa.eu/legal-content/EN/TXT/PDF/?uri=CELEX:32002L0096&from=IT</p>	

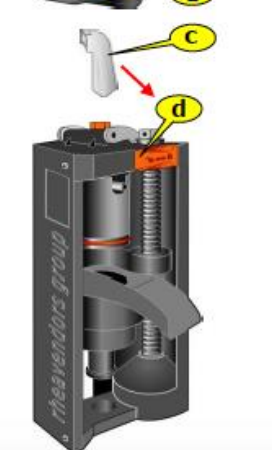
<p>13. how to do to...</p>												
<p>13.01. get an espresso selection</p>	<p>The parameters that determine the quality and quantity of an espresso selection in a cup are:</p> <ul style="list-style-type: none"> ▪ the temperature and quantity of percolation water ▪ the coffee grinding degree ▪ the ground coffee quantity ▪ the ground compression ▪ the features of coffee beans <p>Considering the great variability of these factors, it is important to establish which are the features of the espresso most in demand by the final user and to programme the vending machine components to achieve the best result for this choice.</p> <p>Many of the variables contributing to dispense an espresso can be regulated via software and autonomously programmed for each selection, except for:</p> <ul style="list-style-type: none"> ▪ the water temperature that – once set up – is constant; ▪ the grinding degree of the coffee beans that is manually established and – once set up – is constant; <p>The boiler water temperature is generally set to 92 °C ÷ 94 °C in a vending machine installed in a room where the temperature is as prescribed (5 °C ÷ 35 °C).</p> <p>The grinding degree of the coffee beans – fundamentally established by the distance between the grinding wheels – can be manually adjusted by rotating the regulation ring nut.</p> <p>It is assumed that a grinder with new blades is basically regulated as follows:</p> <ul style="list-style-type: none"> ▪ by turning the regulation ring nut clockwise as far as the stop (minimum distance between the grinding wheels). ▪ by turning the same ring nut counterclockwise by one complete turn plus 5/8 notches; <p>The resulting grinding degree can be considered of reference; you can certainly adapt it to the espresso you wish by varying the distance between the grinding wheels.</p> <p style="text-align: center;">guide lines</p>											
<p>espresso coffee "Italian style" (50 cc. in a cup)</p>	<table border="0"> <tr> <td>boiler water temperature:</td> <td>as above</td> </tr> <tr> <td>grinding degree:</td> <td>as above</td> </tr> <tr> <td>grinding time (for ~ 8.0 gr.)</td> <td>6 sec.</td> </tr> <tr> <td>percolation water time:</td> <td>15 sec.</td> </tr> <tr> <td>brewer pressure:</td> <td>no</td> </tr> </table>	boiler water temperature:	as above	grinding degree:	as above	grinding time (for ~ 8.0 gr.)	6 sec.	percolation water time:	15 sec.	brewer pressure:	no	
boiler water temperature:	as above											
grinding degree:	as above											
grinding time (for ~ 8.0 gr.)	6 sec.											
percolation water time:	15 sec.											
brewer pressure:	no											
<p>espresso coffee "American style" (200 cc. in a cup)</p>	<table border="0"> <tr> <td>boiler water temperature:</td> <td>as above</td> </tr> <tr> <td>grinding degree:</td> <td>as above</td> </tr> <tr> <td>grinding time (for ~ 12.0 gr.)</td> <td>9 sec.</td> </tr> <tr> <td>percolation water time:</td> <td>35 sec.</td> </tr> <tr> <td>brewer pressure:</td> <td>1</td> </tr> </table> <p>The cup results can be certainly adapted to the final user's requests better by changing the parameters above.</p>	boiler water temperature:	as above	grinding degree:	as above	grinding time (for ~ 12.0 gr.)	9 sec.	percolation water time:	35 sec.	brewer pressure:	1	
boiler water temperature:	as above											
grinding degree:	as above											
grinding time (for ~ 12.0 gr.)	9 sec.											
percolation water time:	35 sec.											
brewer pressure:	1											
<p>13.02. insert labels</p>	<p>Open the door and remove the carter; extract the electric connectors of the keyboards; release the holders from the front panel by removing the safety clips; insert the labels into the pockets by observing the machine configuration.</p>											
<p>13.03. empty the drip tray</p>	<p>The drip tray is arranged in its work seat and retained by the notches in the structure; pull toward to remove it.</p>											

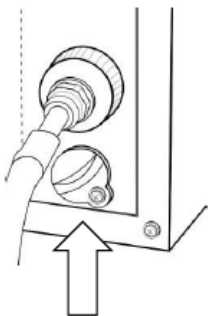
<p>13.04. empty the grounds container</p>	<p>After having opened the door and removed the drip tray, pull the right side of the drawer forward and remove it; observe the position of the water inlet tube of the brewer.</p>	
<p>13.05. remove the coffee hopper</p>	<p>insert the orange closing baffle to the bottom and lift the coffee hopper, pay attention not to spill the content thereof.</p>	
<p>13.06. remove the instant canister</p>	<p>Rotate the dispensing chute closure and pull the canister by lifting it slightly; to reassemble it, insert the rear bush into the motor gear and the lower pin into the horizontal surface hole; ; the product chutes are plug-in mounted and removed from the canisters by turning them clockwise.</p>	
<p>13.07. remove the coffee brewer</p>	<p>After opening the machine, press on each side of the protection carter (a) and remove it by letting the espresso nozzle through the groove after removing it from the nozzle holder (b). Remove the ground grey conveyor by pulling it (c); pull the brewer release button (d), lift and extract it.</p>	
<p>13.08. regulate the grinding degree</p>	<p>Remove the coffee canister; remove the two side covers from the carter; turn the grinder ring nut (clockwise for a finer degree); the effect produced by the regulation is shown by the drink after three or four dispensing cycles.</p>	
<p>13.09. regulate the ground dose</p>	<p>See software "grinder time" and also "13.01. how to get an espresso selection".</p>	
<p>13.10. replace the o-ring of mixing bowls</p>	<p>Remove the silicone tubes intended to dispense the product; turn the orange ring nut clockwise; pull the mixing bowl body and extract the mixer fan; you can now access the w-ring of the motor shaft, the water inlet gaskets of the mixing bowl and the mixing bowl gaskets , as already described by chapter 12.02. monthly.</p>	
<p>13.11. replace the mixer motor</p>	<p>Remove the silicone tubes intended to dispense the product; turn the orange ring nut clockwise and pull the mixing bowl body; unscrew the crosshead by using a PH2 screwdriver and extract the motor; the power supply wires can be removed without any tool.</p>	
<p>13.12. replace the product motor</p>	<p>Remove the product canister; access the rear part of the machine; extract the two small electric cables from the motor, hold the body, push it to the bottom to release it from the bayonet connection of the structure; the power supply wires can be removed without any tool (observe the polarities).</p>	
<p>13.13. determine water and product times</p>	<p>The times specified by table 10.01. can be referred to as the times functional for the machine and the products to be dispensed; however, they can be adapted to the capacity of the user's cups (by changing "time water N") and its tastes (by changing "product N"); please, never forget to make sure that the dispensing time of the instant product is always lower than the one of corresponding water.</p>	
<p>13.14. programme delays</p>	<p>(if accepted) dispensing starts as soon as the user presses a selection key; the order in which instant products are poured into the cup depends upon the values of delays (e.g. the one, the delay value of which is zero, will be dispensed before the one, the value of which is 40, dispensed four seconds after the user has pressed the selection key); pay special attention when programming the delays in dispensing a product and the water diluting it in the mixing bowl; except for the instant coffee product, for which just the opposite is applicable, it is recommended to dispense water before the product to enable the latter to drop on the water film already present in the mixing bowl for a better mix; espresso is dispensed before and after any instant product by programming the variable "coffee sequence".</p>	

<p>13.15. regulate the speed of mixers</p>	<p>The rotation speed of the motors of product mixers can be adjusted between 15,000 r.p.m. and 5,000 r.p.m.; the drink quality of instant products depends a lot upon the action of the fans of mixers: instant chocolate generally requires a long mixing time at the maximum speed for dissolution in water whereas instant tea shall not be mixed to get a drink quality without any bubble on the surface.</p>	
<p>13.16. choose the quantity of break numbers</p>	<p>if instant products can be hardly dissolved in water, it may be of use to stop the product dispensing cycle from the product canister for a short time; the water flowing into the mixing bowl will have the time necessary to remove any product build-up.</p>	
<p>13.17. time tests</p>	<p>To check the rotation time of a product motor and a mixer fan or the activation time of a solenoid valve during the programming phase, when the display shows "PRODUCT N" or "WATER N time" or "MIXER N", press the "PROG" key: the device will be activated for the programmed time.</p>	
<p>13.18. determine the suction fan time</p>	<p>To remove the residual powder of instant products from inside the machine, it is recommended to use the value in minutes you have already programmed (three); if you should use particularly volatile products, increase the time to five (and more) minutes.</p>	
<p>13.19. tune the water flow for instant products</p>	<p>Regulation is admitted for boiler pumps within the +/-30% maximum limits only when the programmed water flow is "average"; when it is "low", it can be only increased (max. by 30%) whereas – when it is "high" - the flow can be only reduced (max. 30%).</p>	
<p>13.20. remove water;</p>	<p>To discharge the water from the machine circuits:</p> <ul style="list-style-type: none"> ▪ detach the water supply, disassemble the rear panel; 	
	<p><u>in Espresso machines:</u></p> <ul style="list-style-type: none"> ▪ connect a tube 6X9 with the drain of the pressured boiler to convey water to a bucket that shall be placed on the floor, having a capacity of at least three litres ▪ power on the machine by means of the service key, access the programming mode -> "miscellaneous" -> "deinstallation"; and follow the instructions ▪ the machine pump will start working to discharge water from the boiler and the tubes into the bucket; the time necessary to discharge is over six minutes to enable water to flow completely ▪ while removing the fastening screw from the plug, extract the drain tube of the air break and empty it by conveying water into the bucket ▪ re-insert the plug into the tube and remount it on the machine by means of its fastening screw ▪ remove the tube from the drain solenoid valve of the boiler 	<div style="background-color: #ffffcc; padding: 5px; text-align: center;"> <p>Deinstallation 10=START</p> </div> 
	<p><u>in Instant machines:</u></p> <ul style="list-style-type: none"> ▪ remove the plug closing the drain tube of the boiler by unscrewing the screw and wait for the water outlet; <p>Re-mount the rear panel of the machine.</p>	
<p>13.21.install a payment system</p>	<p>coffee perfect. is at disposal for any kind of support and information on the installation of payment systems; (see 02.02.).</p>	

14. Eleganza E5 hydraulic diagram

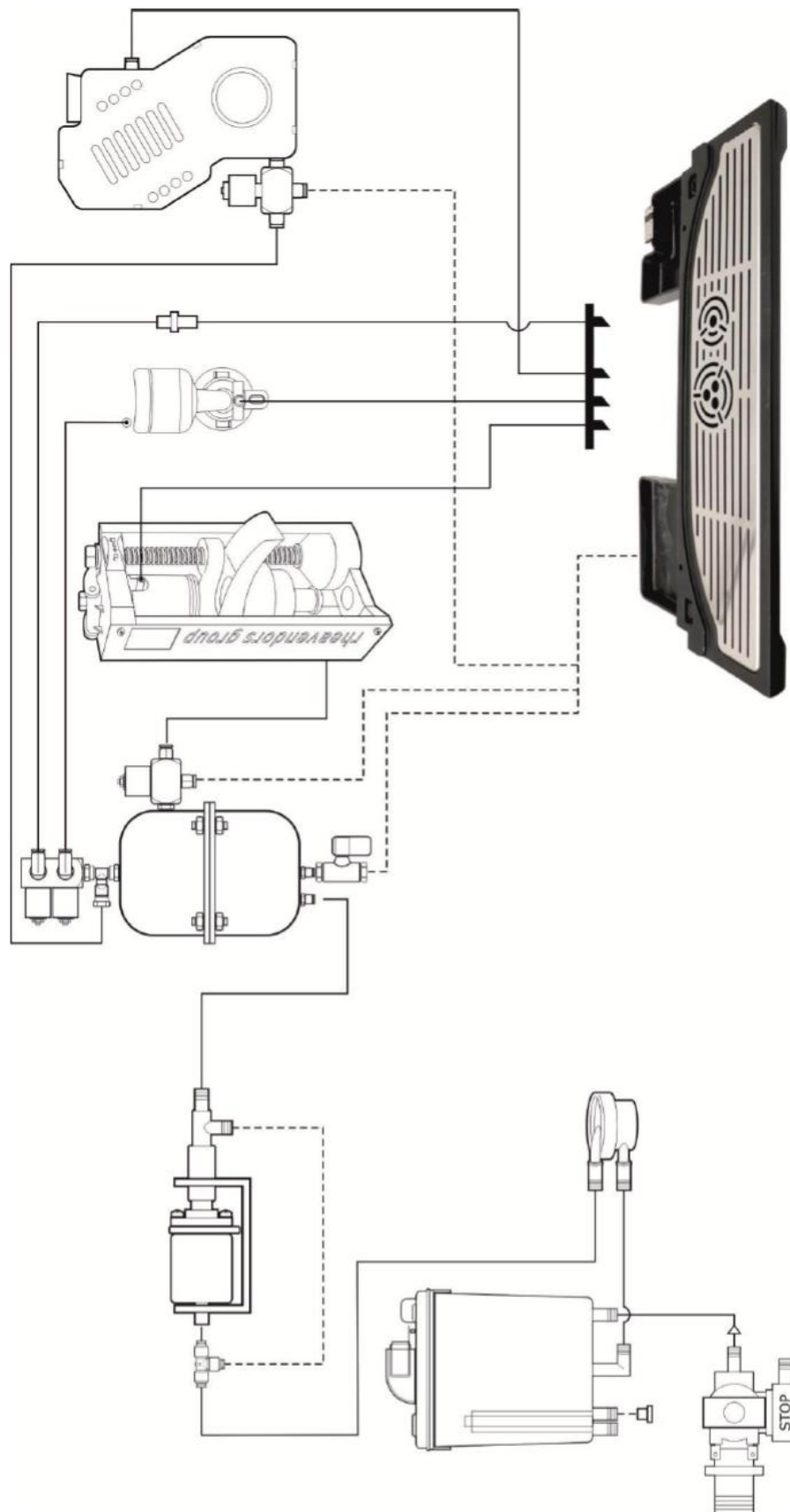

coffee perfect
is a member of CP Denmark A/S
Birk Centerpark 40
7400 Herning | Danmark